

Delta-Gamma Hedge

- Delta hedge is based on the first-order approximation to changes in the derivative price, Δf , due to changes in the stock price, ΔS .
- When ΔS is not small, the second-order term, gamma $\Gamma \triangleq \partial^2 f / \partial S^2$, helps (theoretically).
- A delta-gamma hedge is a delta hedge that maintains zero portfolio gamma; it is gamma neutral.
- To meet this extra condition, one more security needs to be brought in.

Delta-Gamma Hedge (concluded)

- Suppose we want to hedge short calls as before.
- A hedging call f_2 is brought in.
- To set up a delta-gamma hedge, we solve

$$\begin{aligned} -N \times f + n_1 \times S + n_2 \times f_2 - B &= 0 && \text{(self-financing),} \\ -N \times \Delta + n_1 + n_2 \times \Delta_2 - 0 &= 0 && \text{(delta neutrality),} \\ -N \times \Gamma + 0 + n_2 \times \Gamma_2 - 0 &= 0 && \text{(gamma neutrality),} \end{aligned}$$

for n_1 , n_2 , and B .

- The gammas of the stock and bond are 0.
- See the numerical example on pp. 231–232 of the text.

Other Hedges

- If volatility changes, delta-gamma hedge may not work well.
- An enhancement is the delta-gamma-vega hedge, which also maintains vega zero portfolio vega.
- To accomplish this, still one more security has to be brought into the process.
- In practice, delta-vega hedge, which may not maintain gamma neutrality, performs better than delta hedge.

Trees

I love a tree more than a man.
— Ludwig van Beethoven (1770–1827)

All those holes and pebbles.
Who could count them?
— James Joyce, *Ulysses* (1922)

And though the holes were rather small,
they had to count them all.
— The Beatles, *A Day in the Life* (1967)

The Combinatorial Method

- The combinatorial method can often cut the running time by an order of magnitude.
- The basic paradigm is to count the number of admissible paths that lead from the root to any terminal node.
- We first used this method in the linear-time algorithm for standard European option pricing on p. 282.
- We will now apply it to price barrier options.

The Reflection Principle^a

- Imagine a particle at position $(0, -\mathbf{a})$ on the integral lattice that is to reach $(n, -\mathbf{b})$.
- Without loss of generality, assume $\mathbf{a} > 0$ and $\mathbf{b} \geq 0$.
- This particle's movement:

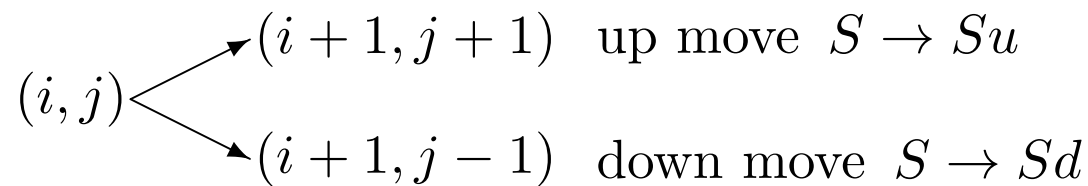

- How many paths touch the x axis?

^aAndré (1887).

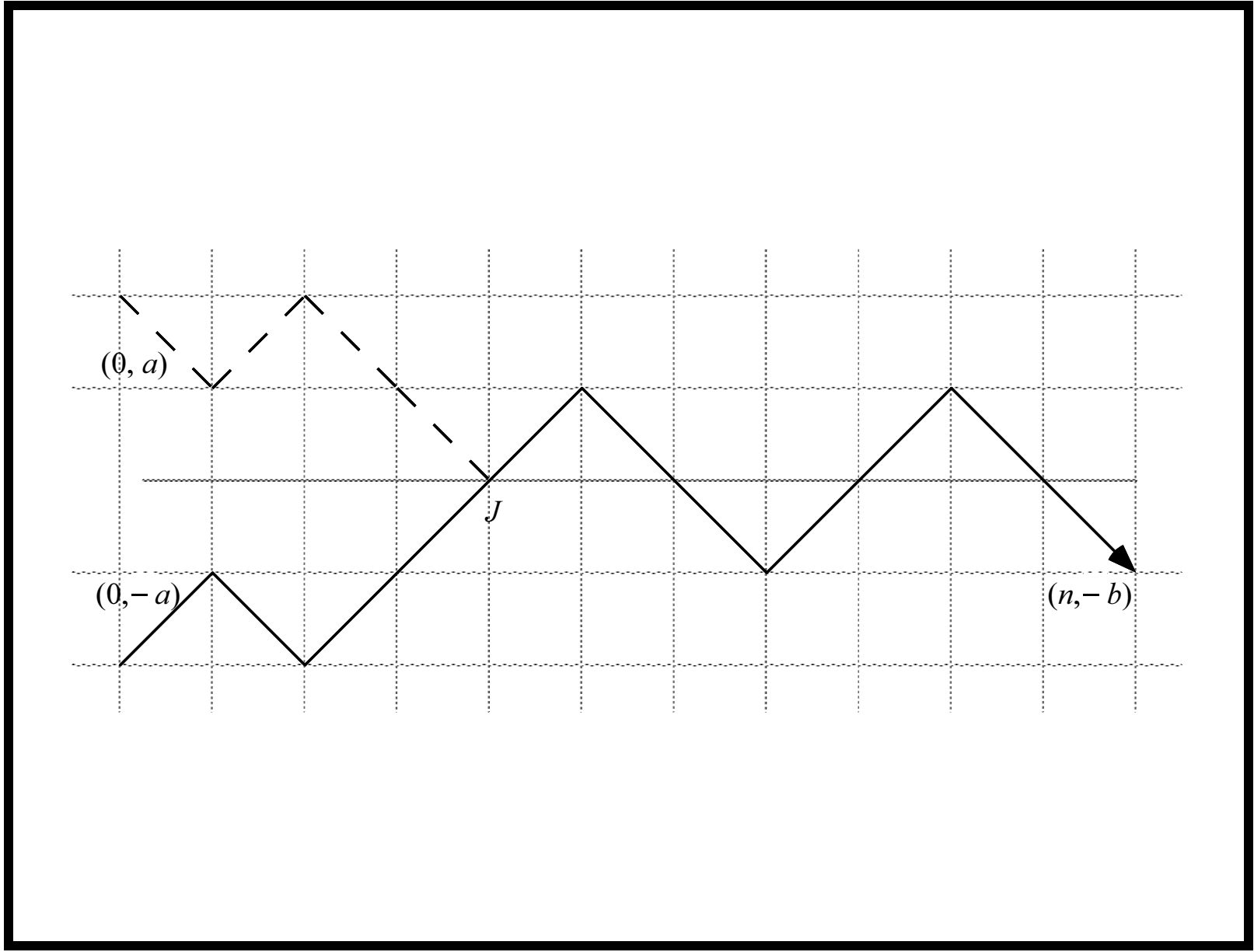

The Reflection Principle (continued)

- For a path from $(0, -\mathbf{a})$ to $(n, -\mathbf{b})$ that touches the x axis, let J denote the first point this happens.
- Reflect the portion of the path from $(0, -\mathbf{a})$ to J .
- A path from $(0, \mathbf{a})$ to $(n, -\mathbf{b})$ is constructed.
- It also hits the x axis at J for the first time.
- The one-to-one mapping shows the number of paths from $(0, -\mathbf{a})$ to $(n, -\mathbf{b})$ that touch the x axis equals the number of paths from $(0, \mathbf{a})$ to $(n, -\mathbf{b})$.

The Reflection Principle (concluded)

- A path of this kind has $(n + \mathbf{b} + \mathbf{a})/2$ down moves and $(n - \mathbf{b} - \mathbf{a})/2$ up moves.^a
- Hence there are

$$\binom{n}{\frac{n+\mathbf{a}+\mathbf{b}}{2}} = \binom{n}{\frac{n-\mathbf{a}-\mathbf{b}}{2}} \quad (94)$$

such paths for *even* $n + \mathbf{a} + \mathbf{b}$.

– Convention: $\binom{n}{k} = 0$ for $k < 0$ or $k > n$.

^aVerify it!

Pricing Barrier Options (Lyu, 1998)

- Focus on the down-and-in call with barrier $H < X$.
- Assume $H < S$ without loss of generality.
- Define

$$a \triangleq \left\lceil \frac{\ln(X/(Sd^n))}{\ln(u/d)} \right\rceil = \left\lceil \frac{\ln(X/S)}{2\sigma\sqrt{\Delta t}} + \frac{n}{2} \right\rceil,$$
$$h \triangleq \left\lfloor \frac{\ln(H/(Sd^n))}{\ln(u/d)} \right\rfloor = \left\lfloor \frac{\ln(H/S)}{2\sigma\sqrt{\Delta t}} + \frac{n}{2} \right\rfloor.$$

- a is such that $\tilde{X} \triangleq Su^a d^{n-a}$ is the *terminal* price that is closest to X from above.
- h is such that $\tilde{H} \triangleq Su^h d^{n-h}$ is the *terminal* price that is closest to H from below.^a

^aSo we underestimate the price.

Pricing Barrier Options (continued)

- The true barrier is replaced by the effective barrier \tilde{H} in the binomial model.
- A process with n moves hence ends up in the money if and only if the number of up moves is at least a .
- The price $Su^k d^{n-k}$ is at a distance of $2k$ from the lowest possible price Sd^n on the binomial tree.

—

$$Su^k d^{n-k} = Sd^{-k} d^{n-k} = Sd^{n-2k}. \quad (95)$$

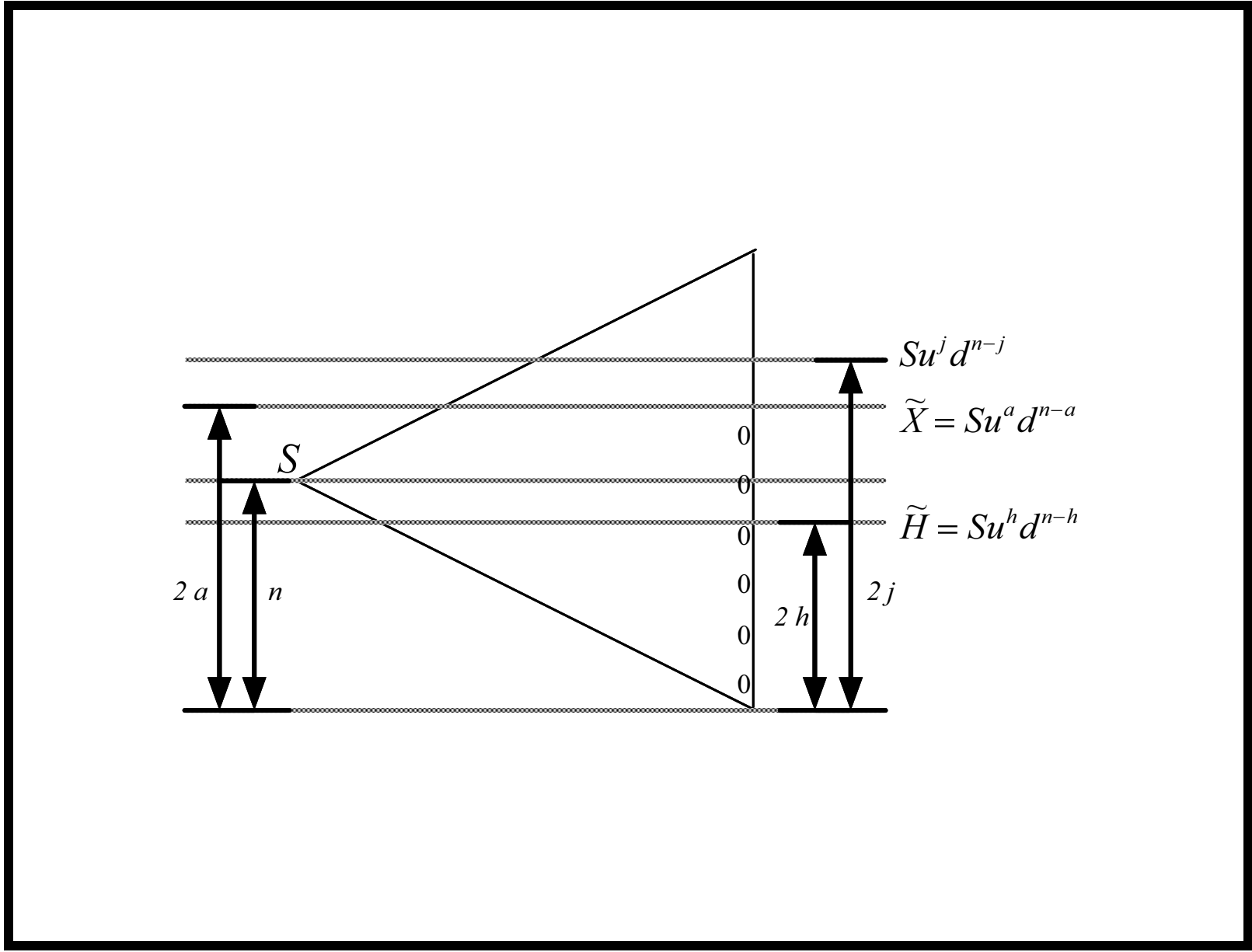

Pricing Barrier Options (continued)

- A path from S to the terminal price $Su^j d^{n-j}$ has probability $p^j(1-p)^{n-j}$ of being taken.
- With reference to p. 716, the reflection principle (p. 711) can be applied with

$$a = n - 2h,$$

$$b = 2j - 2h,$$

in Eq. (94) on p. 713 by treating the \tilde{H} line as the x axis.

Pricing Barrier Options (continued)

- Therefore,

$$\binom{n}{\frac{n+(n-2h)+(2j-2h)}{2}} = \binom{n}{n-2h+j}$$

paths hit \tilde{H} in the process for $h \leq n/2$.

- The terminal price $Su^j d^{n-j}$ is reached by a path that hits the effective barrier with probability

$$\binom{n}{n-2h+j} p^j (1-p)^{n-j}, \quad j \leq 2h.$$

Pricing Barrier Options (concluded)

- The option value equals

$$\frac{\sum_{j=a}^{2h} \binom{n}{n-2h+j} p^j (1-p)^{n-j} (Su^j d^{n-j} - X)}{R^n}. \quad (96)$$

– $R \triangleq e^{r\tau/n}$ is the riskless return per period.

- It yields a linear-time algorithm.^a

^aLyuu (1998).

Convergence of BOPM

- Equation (96) results in the same sawtooth-like convergence shown on p. 404 (repeated on next page).
- The reasons are not hard to see.
- The true barrier H most likely does not equal the effective barrier \tilde{H} .

Convergence of BOPM (continued)

Down-and-in call value

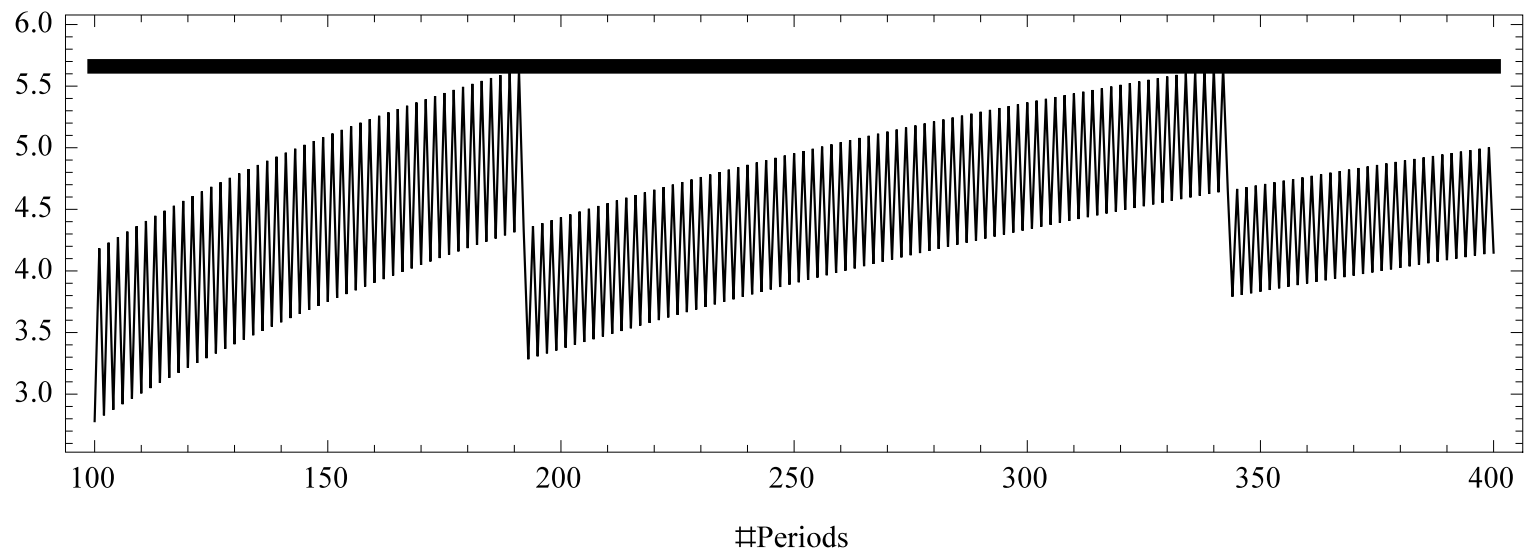

Convergence of BOPM (continued)

- Convergence is actually good if we limit n to certain values—191, for example.
- These values make the true barrier coincide with or just above one of the stock price levels, that is,

$$H \approx Sd^j = Se^{-j\sigma\sqrt{\tau/n}}$$

for some integer j .

- The preferred n 's are thus

$$n = \left\lceil \frac{\tau}{(\ln(S/H)/(j\sigma))^2} \right\rceil, \quad j = 1, 2, 3, \dots$$

Convergence of BOPM (continued)

- There is only one minor technicality left.
- We picked the effective barrier to be one of the $n + 1$ possible *terminal* stock prices.
- However, the effective barrier above, Sd^j , corresponds to a terminal stock price only when $n - j$ is even.^a
- To close this gap, we decrement n by one, if necessary, to make $n - j$ an even number.

^aThis is because $j = n - 2k$ for some k by Eq. (95) on p. 715. Of course we could have adopted the form Sd^j ($-n \leq j \leq n$) for the effective barrier. It makes a good exercise.

Convergence of BOPM (concluded)

- The preferred n 's are now

$$n = \begin{cases} \ell, & \text{if } \ell - j \text{ is even,} \\ \ell - 1, & \text{otherwise,} \end{cases}$$

$j = 1, 2, 3, \dots$, where

$$\ell \triangleq \left\lfloor \frac{\tau}{(\ln(S/H)/(j\sigma))^2} \right\rfloor.$$

- Evaluate pricing formula (96) on p. 719 only with the n 's above.

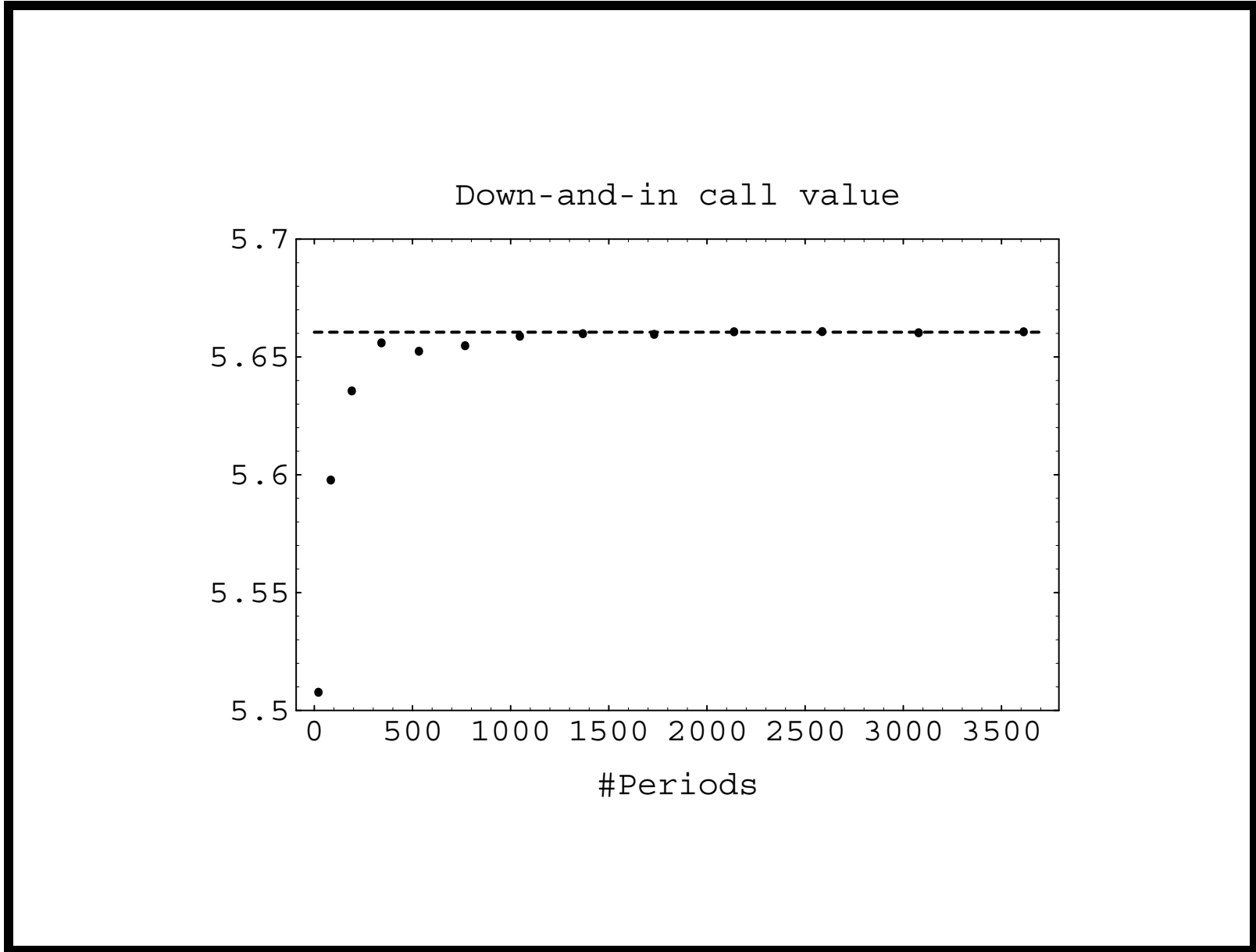

Practical Implications^a

- This binomial model is $O(1/\sqrt{n})$ convergent in general but $O(1/n)$ convergent when the barrier is matched.^b
- Now that barrier options can be efficiently priced, we can afford to pick very large n 's (p. 727).
- This has profound consequences.^c

^aLyu (1998).

^bJ. Lin (R95221010) (2008); ; J. Lin (R95221010) & Palmer (2013).

^cSee pp. 741ff.

n	Combinatorial method	
	Value	Time (milliseconds)
21	5.507548	0.30
84	5.597597	0.90
191	5.635415	2.00
342	5.655812	3.60
533	5.652253	5.60
768	5.654609	8.00
1047	5.658622	11.10
1368	5.659711	15.00
1731	5.659416	19.40
2138	5.660511	24.70
2587	5.660592	30.20
3078	5.660099	36.70
3613	5.660498	43.70
4190	5.660388	44.10
4809	5.659955	51.60
5472	5.660122	68.70
6177	5.659981	76.70
6926	5.660263	86.90
7717	5.660272	97.20

Practical Implications (concluded)

- Pricing is prohibitively time consuming when $S \approx H$ because

$$n \sim 1/\ln^2(S/H).$$

- This is called the barrier-too-close problem.
- This observation is indeed true of standard quadratic-time binomial tree algorithms.
- But it no longer applies to linear-time algorithms (see p. 729).

Barrier at 95.0			Barrier at 99.5			Barrier at 99.9		
<i>n</i>	Value	Time	<i>n</i>	Value	Time	<i>n</i>	Value	Time
	.							
	.		795	7.47761	8	19979	8.11304	253
2743	2.56095	31.1	3184	7.47626	38	79920	8.11297	1013
3040	2.56065	35.5	7163	7.47682	88	179819	8.11300	2200
3351	2.56098	40.1	12736	7.47661	166	319680	8.11299	4100
3678	2.56055	43.8	19899	7.47676	253	499499	8.11299	6300
4021	2.56152	48.1	28656	7.47667	368	719280	8.11299	8500
True	2.5615			7.4767			8.1130	

(All times in milliseconds.)

Trinomial Tree

- Set up a trinomial approximation to the geometric Brownian motion^a

$$\frac{dS}{S} = r dt + \sigma dW.$$

- The three stock prices at time Δt are S , Su , and Sd , where $ud = 1$.
- Let the mean and variance of the stock price be SM and S^2V , respectively.

^aBoyle (1988).

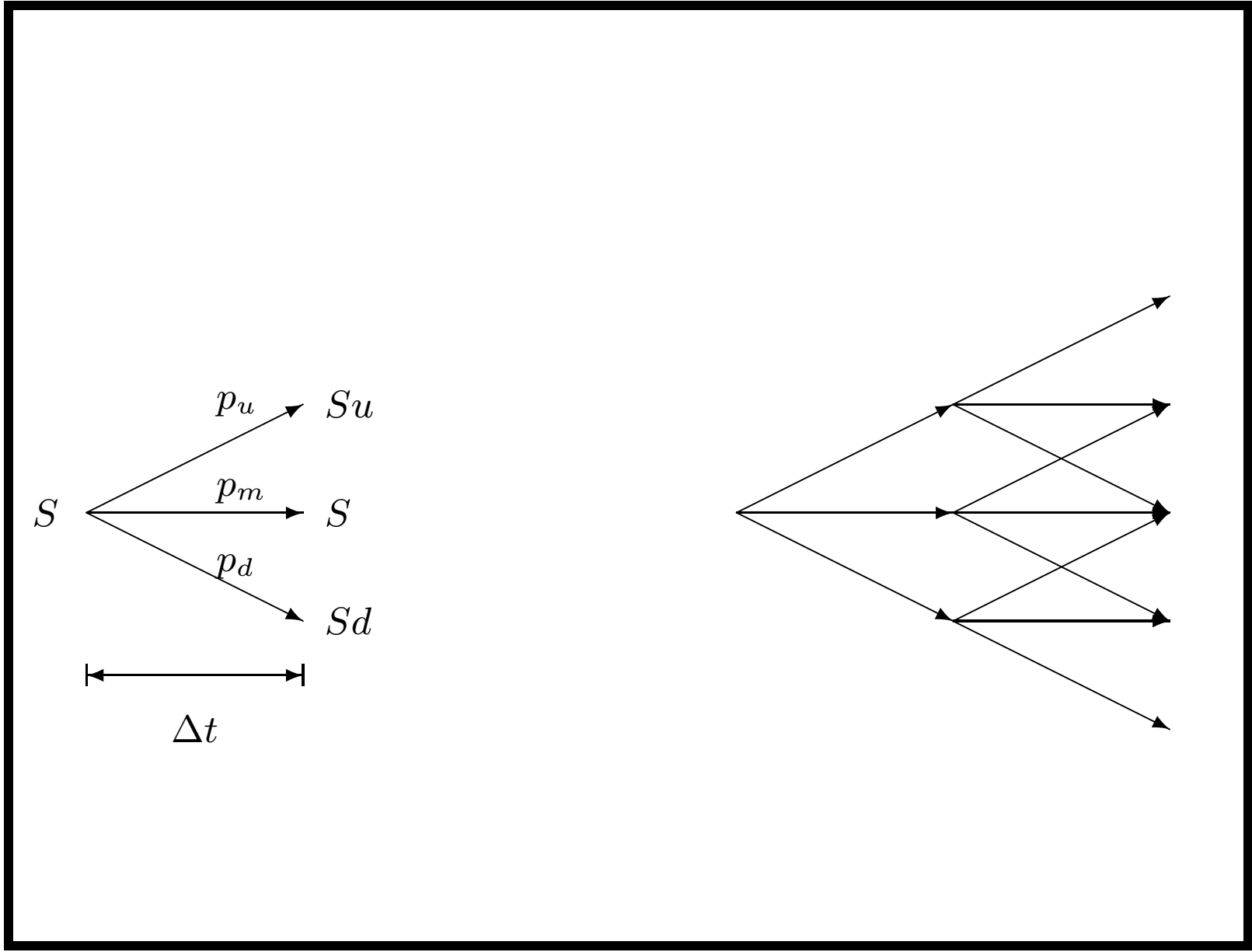

Trinomial Tree (continued)

- By Eqs. (29) on p. 180,

$$M \triangleq e^{r\Delta t},$$
$$V \triangleq M^2(e^{\sigma^2\Delta t} - 1).$$

- Impose the matching of mean and that of variance:

$$1 = p_u + p_m + p_d,$$

$$SM = (p_u u + p_m + (p_d/u)) S,$$

$$S^2V = p_u(Su - SM)^2 + p_m(S - SM)^2 + p_d(Sd - SM)^2.$$

Trinomial Tree (continued)

- Use linear algebra to verify that

$$p_u = \frac{u(V + M^2 - M) - (M - 1)}{(u - 1)(u^2 - 1)},$$
$$p_d = \frac{u^2(V + M^2 - M) - u^3(M - 1)}{(u - 1)(u^2 - 1)}.$$

- We must also make sure the probabilities lie between 0 and 1.

Trinomial Tree (concluded)

- There are countless variations.
- But all converge to the Black-Scholes option pricing model.^a
- The trinomial model has a linear-time algorithm for European options.^b

^aMadan, Milne, & Shefrin (1989).

^bT. Chen (R94922003) (2007).

A Trinomial Tree

- Use $u = e^{\lambda\sigma\sqrt{\Delta t}}$, where $\lambda \geq 1$ is a tunable parameter.
- Then

$$p_u \rightarrow \frac{1}{2\lambda^2} + \frac{(r + \sigma^2)\sqrt{\Delta t}}{2\lambda\sigma},$$
$$p_d \rightarrow \frac{1}{2\lambda^2} - \frac{(r - 2\sigma^2)\sqrt{\Delta t}}{2\lambda\sigma}.$$

- A nice choice for λ is $\sqrt{\pi/2}$.^a

^aOmberg (1988).

Barrier Options Revisited

- BOPM introduces a specification error by replacing the barrier with a nonidentical effective barrier.
- The trinomial model solves the problem by adjusting λ so that the barrier is hit exactly.^a

- When

$$S e^{-h\lambda\sigma\sqrt{\Delta t}} = H,$$

it takes h down moves to go from S to H , if h is an integer.

- Then

$$h = \frac{\ln(S/H)}{\lambda\sigma\sqrt{\Delta t}}.$$

^aRitchken (1995).

Barrier Options Revisited (continued)

- This is easy to achieve by adjusting λ .
- Typically, we find the smallest $\lambda \geq 1$ such that h is an integer.^a
 - Such a λ may not exist for very small n 's.
 - This is not hard to check.
- Toward that end, we find the *largest* integer $j \geq 1$ that satisfies $\frac{\ln(S/H)}{j\sigma\sqrt{\Delta t}} \geq 1$ to be our h .
- Then let

$$\lambda = \frac{\ln(S/H)}{h\sigma\sqrt{\Delta t}}.$$

^aWhy must $\lambda \geq 1$?

Barrier Options Revisited (continued)

- Alternatively, we can pick

$$h = \left\lceil \frac{\ln(S/H)}{\sigma\sqrt{\Delta t}} \right\rceil.$$

- Make sure $h \geq 1$.
- Then let

$$\lambda = \frac{\ln(S/H)}{h\sigma\sqrt{\Delta t}}.$$

Barrier Options Revisited (concluded)

- This done, one of the layers of the trinomial tree coincides with the barrier.
- The following probabilities may be used,

$$p_u = \frac{1}{2\lambda^2} + \frac{\mu' \sqrt{\Delta t}}{2\lambda\sigma},$$

$$p_m = 1 - \frac{1}{\lambda^2},$$

$$p_d = \frac{1}{2\lambda^2} - \frac{\mu' \sqrt{\Delta t}}{2\lambda\sigma}.$$

$$- \mu' \triangleq r - (\sigma^2/2).$$

Down-and-in call value

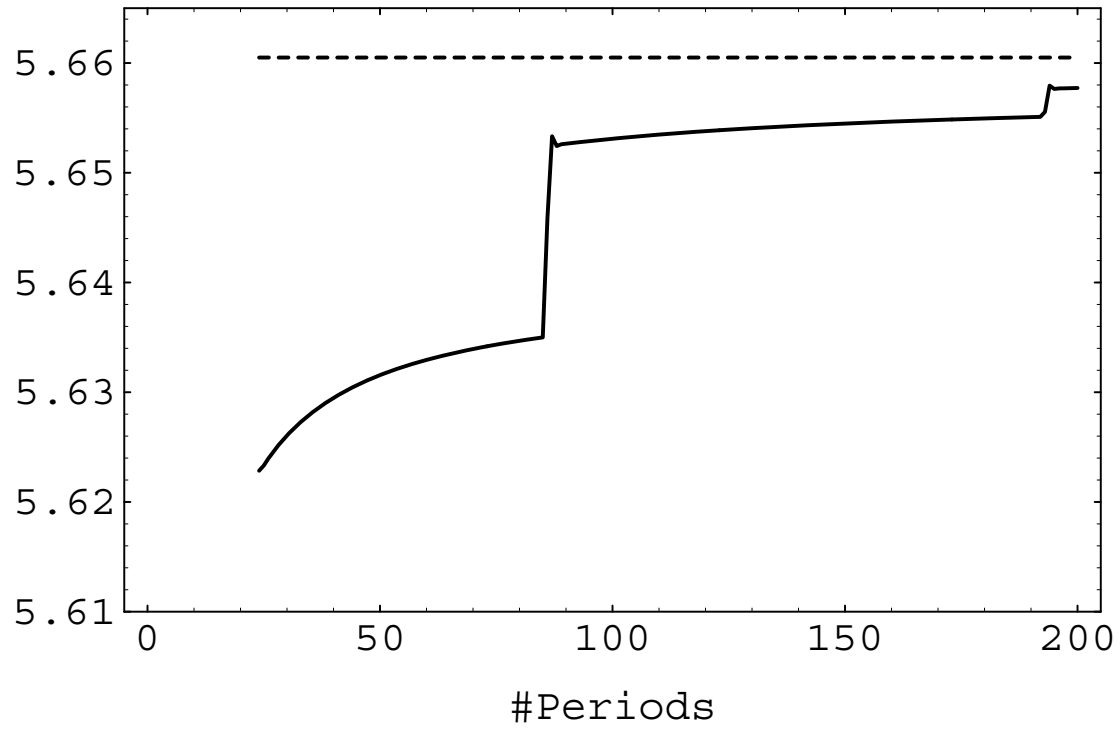

Algorithms Comparison^a

- So which algorithm is better, binomial or trinomial?
- Algorithms are often compared based on the n value at which they converge.
 - The one with the smallest n wins.
- So giraffes are faster than cheetahs because they take fewer strides to travel the same distance!
- Performance must be based on actual running times, not n .^b

^aLyu (1998).

^bPatterson & Hennessy (1994).

Algorithms Comparison (continued)

- Pages 721 and 740 seem to show the trinomial model converges at a smaller n than BOPM.
- It is in this sense when people say trinomial models *converge* faster than binomial ones.
- But does it make the trinomial model better then?

Algorithms Comparison (concluded)

- The linear-time binomial tree algorithm actually performs better than the trinomial one.
- See the next page, expanded from p. 727.
- The barrier-too-close problem is also too hard for a quadratic-time trinomial tree algorithm.^a
 - See pp. 754ff for an alternative solution.

^aLyu (1998).

n	Combinatorial method		Trinomial tree algorithm	
	Value	Time	Value	Time
21	5.507548	0.30		
84	5.597597	0.90	5.634936	35.0
191	5.635415	2.00	5.655082	185.0
342	5.655812	3.60	5.658590	590.0
533	5.652253	5.60	5.659692	1440.0
768	5.654609	8.00	5.660137	3080.0
1047	5.658622	11.10	5.660338	5700.0
1368	5.659711	15.00	5.660432	9500.0
1731	5.659416	19.40	5.660474	15400.0
2138	5.660511	24.70	5.660491	23400.0
2587	5.660592	30.20	5.660493	34800.0
3078	5.660099	36.70	5.660488	48800.0
3613	5.660498	43.70	5.660478	67500.0
4190	5.660388	44.10	5.660466	92000.0
4809	5.659955	51.60	5.660454	130000.0
5472	5.660122	68.70		
6177	5.659981	76.70		

(All times in milliseconds.)

Double-Barrier Options

- Double-barrier options are barrier options with two barriers $L < H$.
 - They make up “less than 5% of the light exotic market.”^a
- Assume $L < S < H$.
- The binomial model produces oscillating option values (see plot on next page).^b

^aBennett (2014).

^bChao (R86526053) (1999); Dai (B82506025, R86526008, D8852600) & Lyuu (2005).

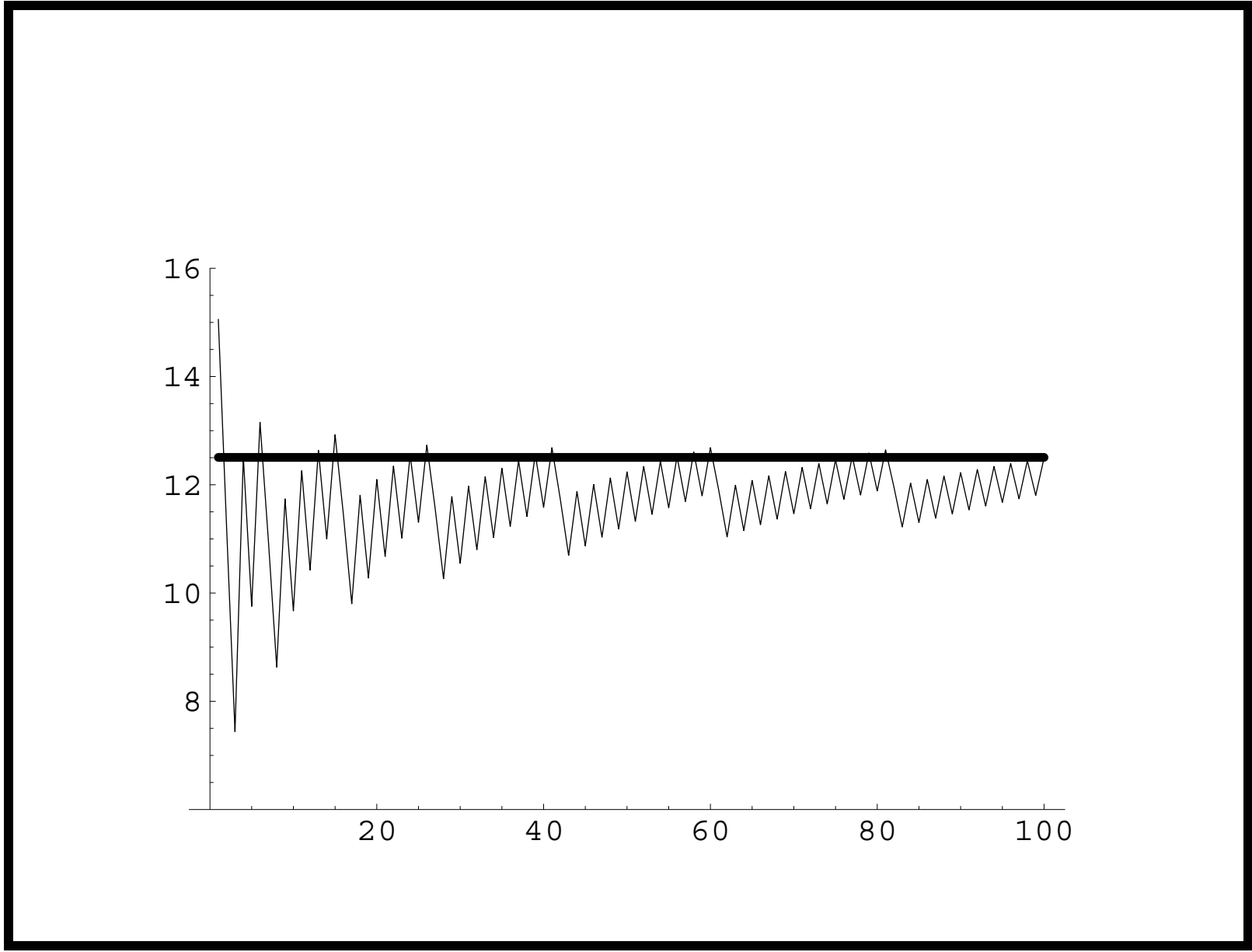

Double-Barrier Options (concluded)

- The combinatorial method yields a linear-time algorithm.^a
- This binomial model is $O(1/\sqrt{n})$ convergent in general.^b
- If the barriers L and H depend on time, we have moving-barrier options.^c

^aSee p. 241 of the textbook.

^bGobet (1999).

^cRogers & Zane (1998).

Double-Barrier Knock-Out Options

- We knew how to pick the λ so that one of the layers of the trinomial tree coincides with one barrier, say H .
- This choice, however, does not guarantee that the other barrier, L , is also hit.
- One way to handle this problem is to *lower* the layer of the tree just above L to coincide with L .^a
 - More general ways to make the trinomial model hit both barriers are available.^b

^aRitchken (1995); Hull (1999).

^bHsu (R7526001, D89922012) & Lyuu (2006). Dai (B82506025, R86526008, D8852600) & Lyuu (2006) combine binomial and trinomial trees to derive an $O(n)$ -time algorithm for double-barrier options (see pp. 754ff).

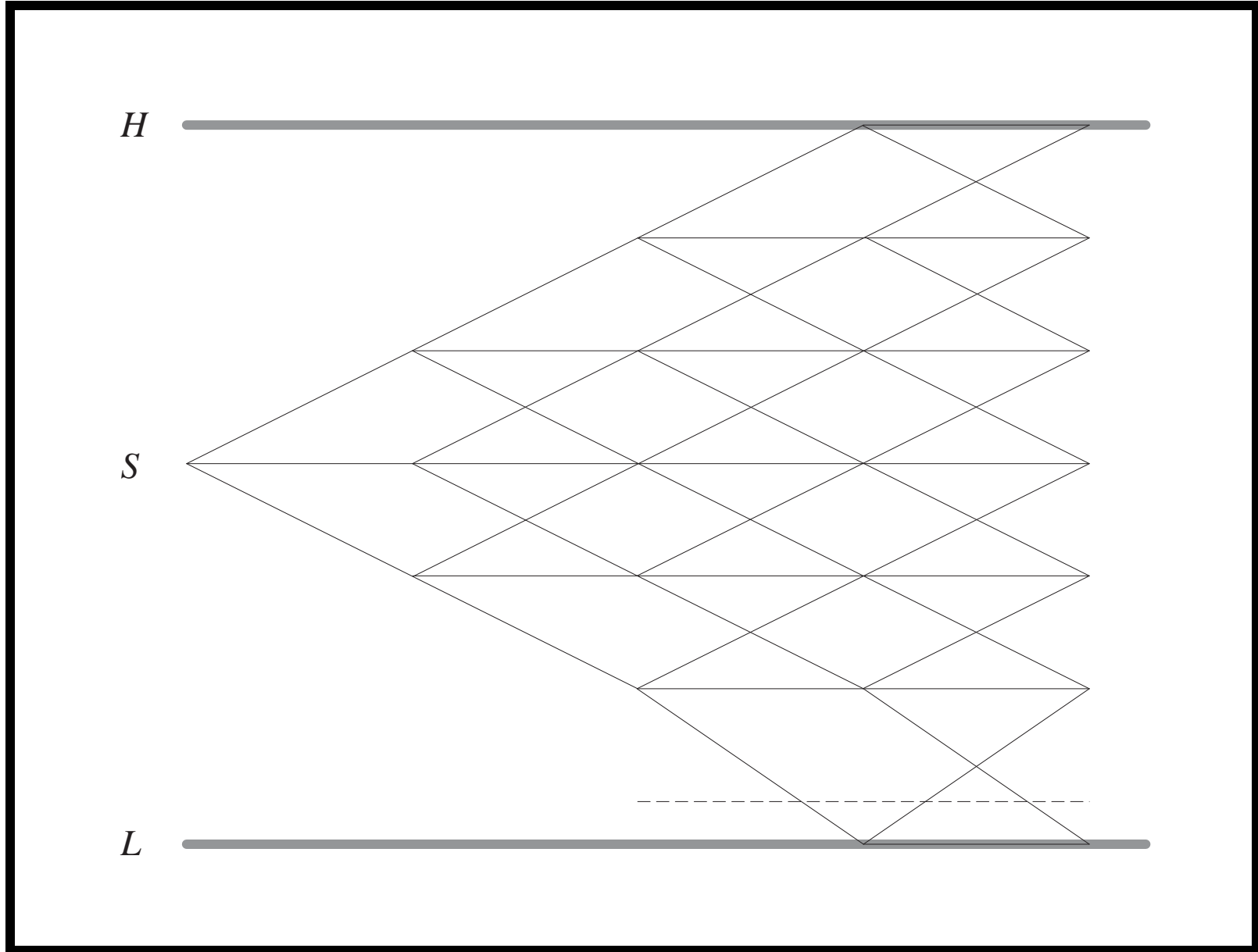

Double-Barrier Knock-Out Options (continued)

- The probabilities of the nodes on the layer above L must be adjusted.
- Let ℓ be the positive integer such that

$$Sd^{\ell+1} < L < Sd^{\ell}.$$

- Hence the layer of the tree just above L has price Sd^{ℓ} .^a

^aYou probably cannot do the same thing for binomial models (why?).
Thanks to a lively discussion on April 25, 2012.

Double-Barrier Knock-Out Options (concluded)

- Define $\gamma > 1$ as the number satisfying

$$L = Sd^{\ell-1}e^{-\gamma\lambda\sigma\sqrt{\Delta t}}.$$

- The prices between the barriers are (from low to high)

$$L, Sd^{\ell-1}, \dots, Sd^2, Sd, S, Su, Su^2, \dots, Su^{h-1}, Su^h = H.$$

- The probabilities for the nodes with price equal to $Sd^{\ell-1}$ are

$$p'_u = \frac{b + a\gamma}{1 + \gamma}, \quad p'_d = \frac{b - a}{\gamma + \gamma^2}, \quad \text{and} \quad p'_m = 1 - p'_u - p'_d,$$

where $a \triangleq \mu'\sqrt{\Delta t}/(\lambda\sigma)$ and $b \triangleq 1/\lambda^2$.

Convergence: Binomial vs. Trinomial

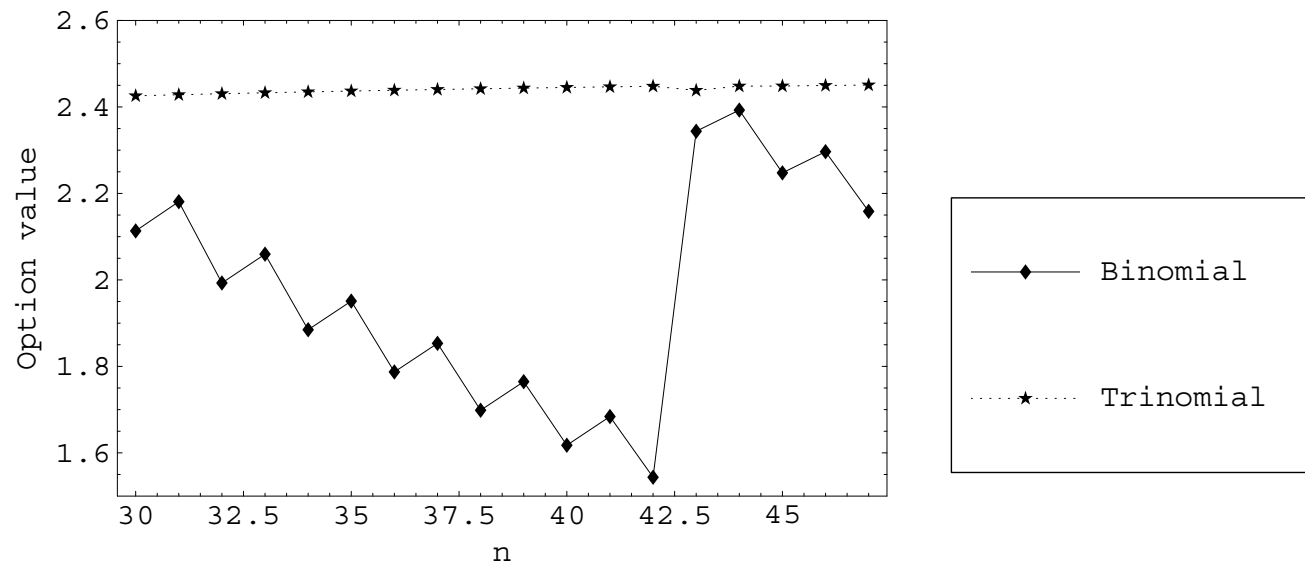

Ideas for Binomial Trees To Handle Two Barriers

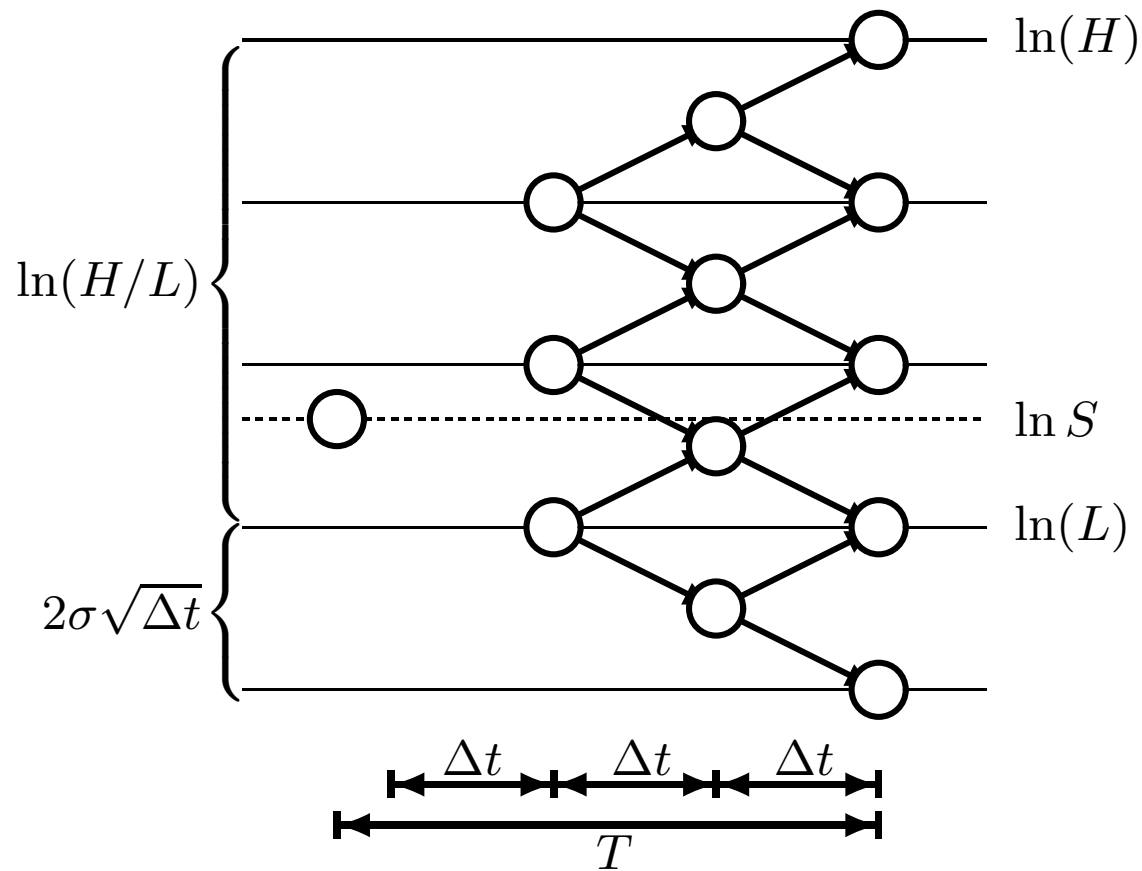

The Binomial-Trinomial Tree

- Append a trinomial structure to a binomial tree can lead to improved convergence and efficiency.^a
- The resulting tree is called the binomial-trinomial tree.^b
- Suppose a *binomial* tree will be built with Δt as the duration of one period.
- Node X at time t needs to pick three nodes on the binomial tree at time $t + \Delta t'$ as its successor nodes.
 - Later, $\Delta t \leq \Delta t' < 2\Delta t$.

^aDai (B82506025, R86526008, D8852600) & Lyuu (2006, 2008, 2010).

^bThe idea first emerged in a hotel in Muroran, Hokkaido, Japan, in May of 2005.

The Binomial-Trinomial Tree (continued)

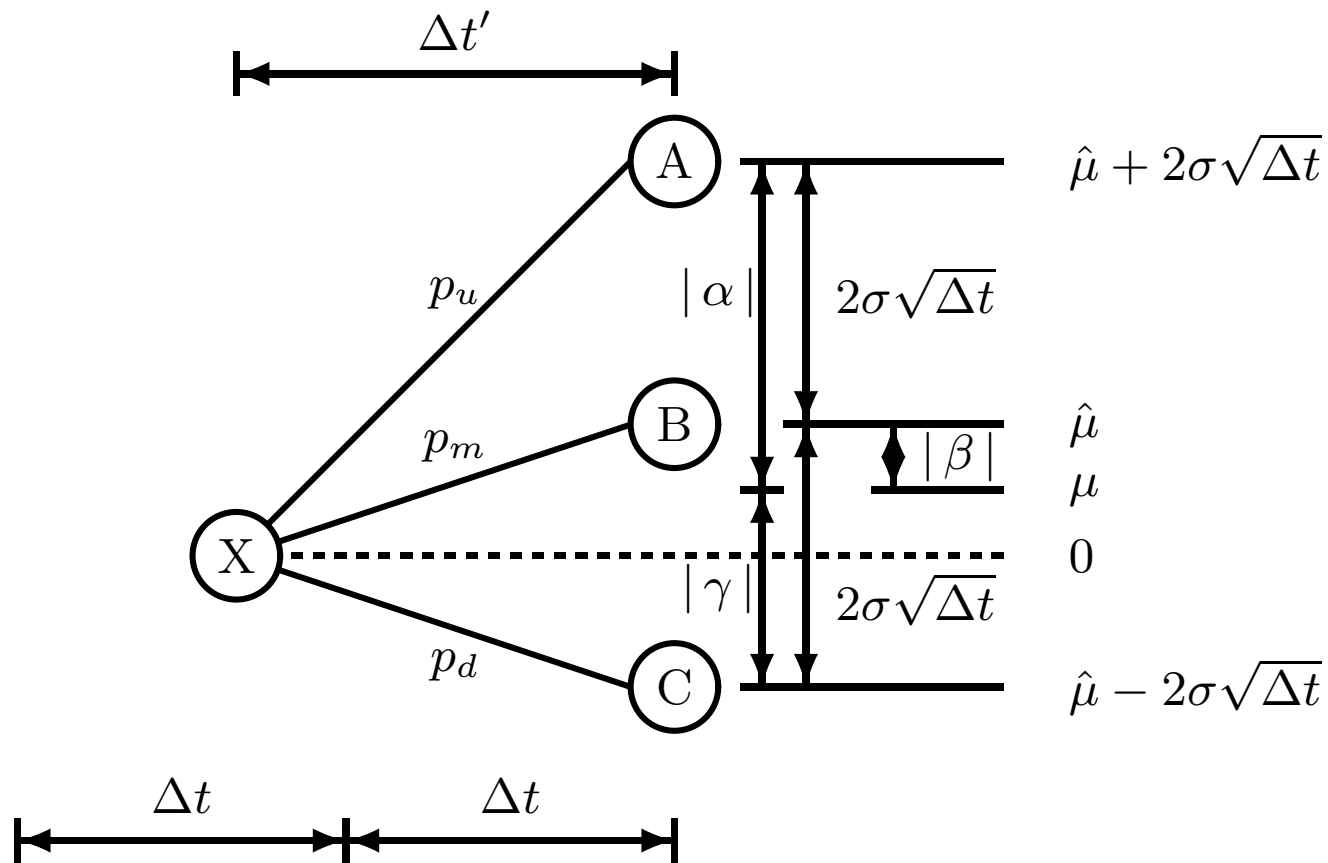

The Binomial-Trinomial Tree (continued)

- These three nodes should guarantee:
 1. The mean and variance of the stock price are matched.
 2. The branching probabilities are between 0 and 1.
- Let S be the stock price at node X .
- Use $s(z)$ to denote the stock price at node z .

The Binomial-Trinomial Tree (continued)

- Recall that the expected value of the logarithmic return $\ln(S_{t+\Delta t'}/S)$ at time $t + \Delta t'$ equals^a

$$\mu \triangleq \left(r - \frac{\sigma^2}{2} \right) \Delta t'. \quad (97)$$

- Its variance equals

$$\text{Var} \triangleq \sigma^2 \Delta t'. \quad (98)$$

- Let node B be the node whose logarithmic return $\hat{\mu} \triangleq \ln(s(\text{B})/S)$ is closest to μ among all the nodes at time $t + \Delta t'$.

^aSee p. 297.

The Binomial-Trinomial Tree (continued)

- The middle branch from node X will end at node B.
- The two nodes A and C, which bracket node B, are the destinations of the other two branches from node X.
- Recall that adjacent nodes on the binomial tree are spaced at $2\sigma\sqrt{\Delta t}$ apart.
- Review the illustration on p. 755.

The Binomial-Trinomial Tree (continued)

- The three branching probabilities from node X are obtained through matching the mean and variance of the logarithmic return $\ln(S_{t+\Delta t'}/S)$.

- Recall that

$$\hat{\mu} \triangleq \ln(s(B)/S)$$

is the logarithmic return of the middle node B.

- Let α , β , and γ be the differences between μ and the logarithmic returns

$$\ln(s(Z)/S), \quad Z = A, B, C,$$

in that order.

The Binomial-Trinomial Tree (continued)

- In other words,

$$\alpha \triangleq \hat{\mu} + 2\sigma\sqrt{\Delta t} - \mu = \beta + 2\sigma\sqrt{\Delta t}, \quad (99)$$

$$\beta \triangleq \hat{\mu} - \mu, \quad (100)$$

$$\gamma \triangleq \hat{\mu} - 2\sigma\sqrt{\Delta t} - \mu = \beta - 2\sigma\sqrt{\Delta t}. \quad (101)$$

- The three branching probabilities p_u, p_m, p_d then satisfy

$$p_u\alpha + p_m\beta + p_d\gamma = 0, \quad (102)$$

$$p_u\alpha^2 + p_m\beta^2 + p_d\gamma^2 = \text{Var}, \quad (103)$$

$$p_u + p_m + p_d = 1. \quad (104)$$

The Binomial-Trinomial Tree (concluded)

- Equation (102) matches the mean (97) of the logarithmic return $\ln(S_{t+\Delta t'} / S)$ on p. 757.
- Equation (103) matches its variance (98) on p. 757.
- The three probabilities can be proved to lie between 0 and 1 by Cramer's rule.

Pricing Double-Barrier Options

- Consider a double-barrier option with two barriers L and H , where $L < S < H$.
- We need to make each barrier coincide with a layer of the binomial tree for better convergence.
- The idea is to choose a Δt such that

$$\frac{\ln(H/L)}{2\sigma\sqrt{\Delta t}} \quad (105)$$

is a positive integer.

- The distance between two adjacent nodes such as nodes Y and Z in the figure on p. 763 is $2\sigma\sqrt{\Delta t}$.

Pricing Double-Barrier Options (continued)

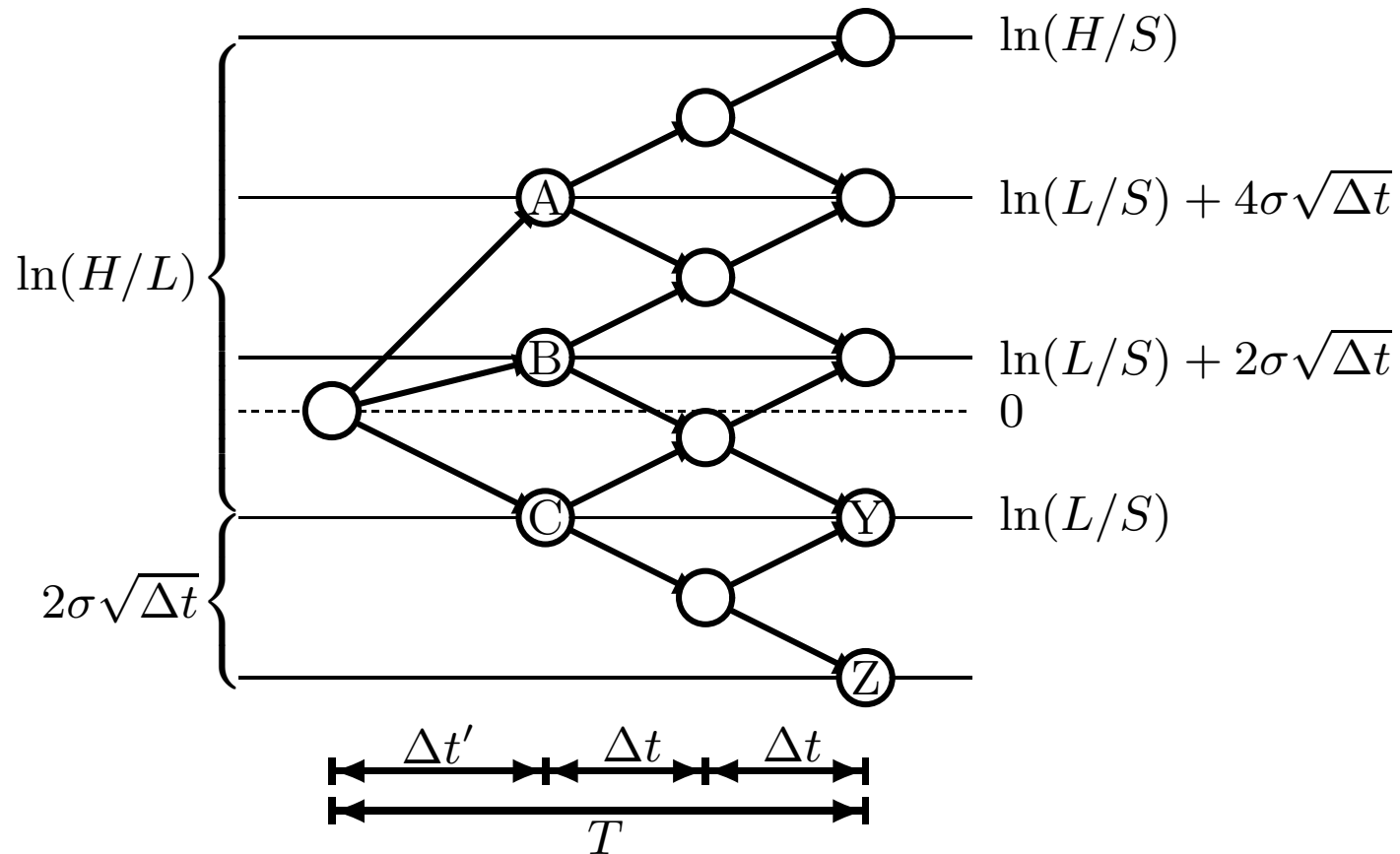

Pricing Double-Barrier Options (continued)

- Suppose that the goal is a tree with $\sim m$ periods.
- Suppose we pick $\Delta\tau \triangleq T/m$ for the length of each period.
- There is no guarantee that $\frac{\ln(H/L)}{2\sigma\sqrt{\Delta\tau}}$ is an integer.
- So we pick a Δt that is close to, but does not exceed, $\Delta\tau$ and makes $\frac{\ln(H/L)}{2\sigma\sqrt{\Delta t}}$ some integer κ .
- Specifically, we select

$$\Delta t = \left(\frac{\ln(H/L)}{2\kappa\sigma} \right)^2,$$

where $\kappa = \left\lceil \frac{\ln(H/L)}{2\sigma\sqrt{\Delta\tau}} \right\rceil$.

Pricing Double-Barrier Options (continued)

- We now proceed to build the binomial-trinomial tree.
- Start with the binomial part.
- Lay out the nodes from the low barrier L upward.
- Automatically, a layer coincides with the high barrier H .
- It is unlikely that Δt divides T , however.
- The position at time 0 and with logarithmic return $\ln(S/S) = 0$ is unlikely on a layer of the binomial tree.^a

^aRecall p. 763.

Pricing Double-Barrier Options (continued)

- The binomial-trinomial structure can address this problem as follows.
- Between time 0 and time T , the binomial tree spans $\lfloor T/\Delta t \rfloor$ periods.
- Keep only the last $\lfloor T/\Delta t \rfloor - 1$ periods and let the first period have a duration equal to

$$\Delta t' \triangleq T - \left(\left\lfloor \frac{T}{\Delta t} \right\rfloor - 1 \right) \Delta t.$$

- Then these $\lfloor T/\Delta t \rfloor$ periods span T years.
- It is easy to verify that $\Delta t \leq \Delta t' < 2\Delta t$.

Pricing Double-Barrier Options (continued)

- Start with the root node at time 0 and at a price with logarithmic return $\ln(S/S) = 0$.
- Find the three nodes on the binomial tree at time $\Delta t'$ as described earlier.
- Calculate the three branching probabilities to them.
- Grow the binomial tree from these three nodes until time T to obtain a binomial-trinomial tree with $\lfloor T/\Delta t \rfloor$ periods.
- Review the illustration on p. 763.

Pricing Double-Barrier Options (continued)

- Now the binomial-trinomial tree can be used to price double-barrier options by backward induction.
- That takes quadratic time.
- But a linear-time algorithm exists for double-barrier options on the *binomial* tree.^a
- Apply that algorithm to price the double-barrier option's prices at the three nodes at time $\Delta t'$.
 - That is, nodes A, B, and C on p. 763.
- Then calculate their expected discounted value for the root node.

^aSee p. 241 of the textbook; Chao (R86526053) (1999); Dai (B82506025, R86526008, D8852600) & Lyuu (2008).

Pricing Double-Barrier Options (continued)

- The overall running time is only linear!
- Binomial trees have troubles pricing barrier options.^a
- Even pit against the trinomial tree, the binomial-trinomial tree converges faster and smoother.^b
- In fact, the binomial-trinomial tree has an error of $O(1/n)$ for single-barrier options.^c
- It has an error of $O(1/n^{1-a})$ for any $0 < a < 1$ for double-barrier options.^d

^aSee p. 404, p. 746, and p. 752.

^bSee p. 770 and p. 771.

^cLyu & Palmer (2010).

^dAppolloni, Gaudenziy, & Zanette (2014).

Pricing Double-Barrier Options^a (continued)

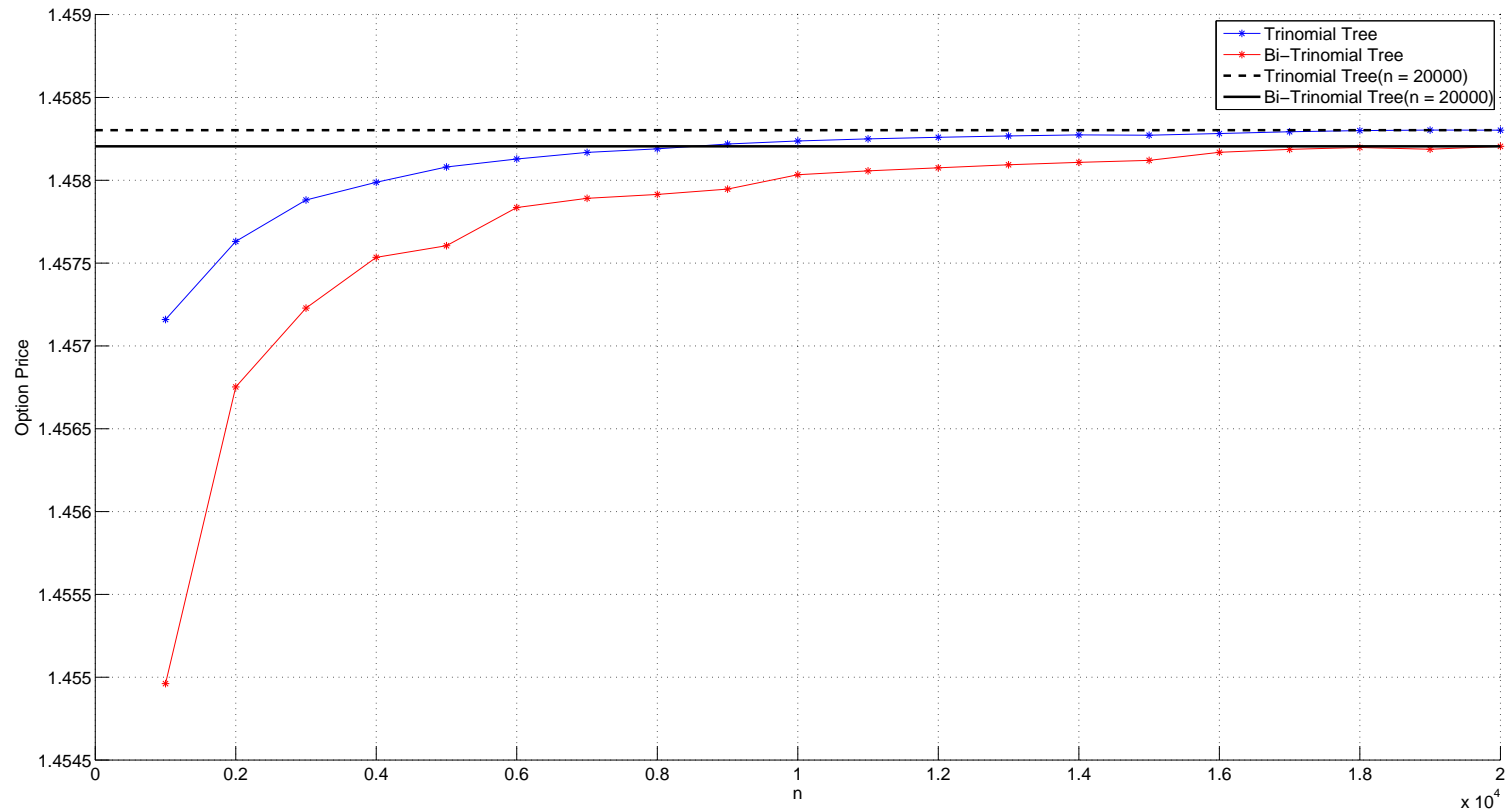

^aGenerated by Mr. Lin, Ying-Hung (R01723029) on June 6, 2014.

Pricing Double-Barrier Options (concluded)

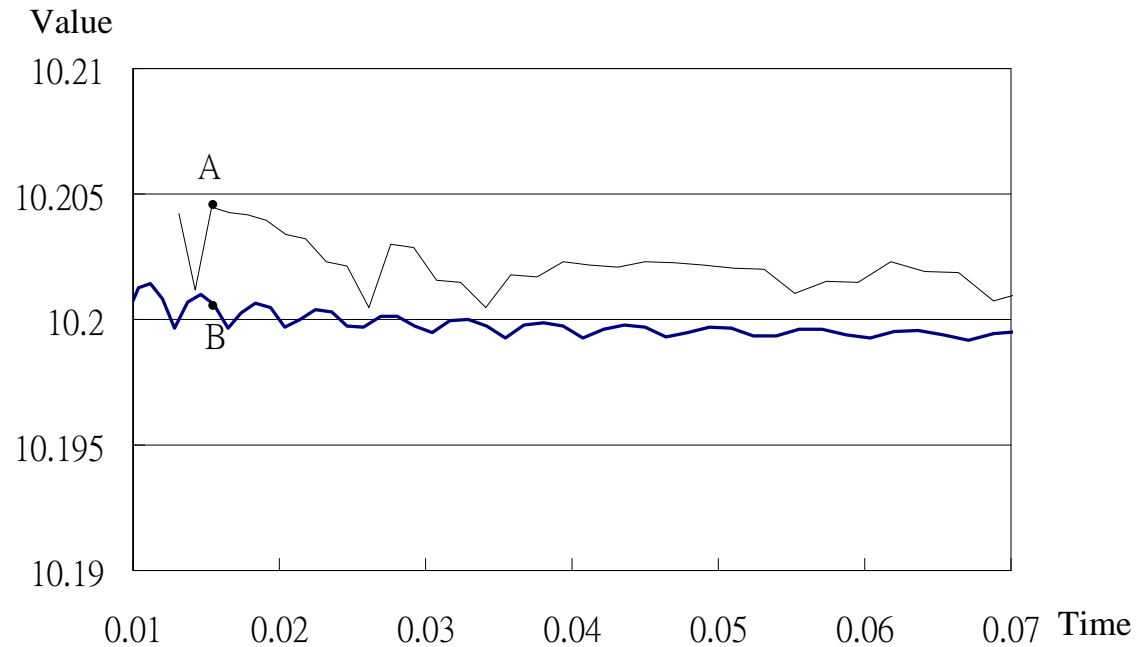

The thin line denotes the double-barrier option prices computed by the trinomial tree against the running time in seconds (such as point A). The thick line denotes those computed by the binomial-trinomial tree (such as point B).

The Barrier-Too-Close Problem (p. 728) Revisited

- Our idea solves it even if one barrier is very close to S .
 - It runs in linear time, unlike an earlier quadratic-time solution with trinomial trees (pp. 736ff).
 - Unlike an earlier solution using combinatorics (p. 719), now the choice of n is not that restricted.
- So it combines the strengths of binomial and trinomial trees.
- This holds for single-barrier options too.
- Here is how.

The Barrier-Too-Close Problem Revisited (continued)

- We can build the tree treating S as if it were a second barrier.
- So both H and S are matched.
- Alternatively, we can pick $\Delta\tau \triangleq T/m$ as our length of a period Δt without the subsequent adjustment.^a
- Then build the tree from the price H down.
- So H is matched.
- The initial price S is automatically matched by the *trinomial* structure.

^aThere is no second barrier to match!

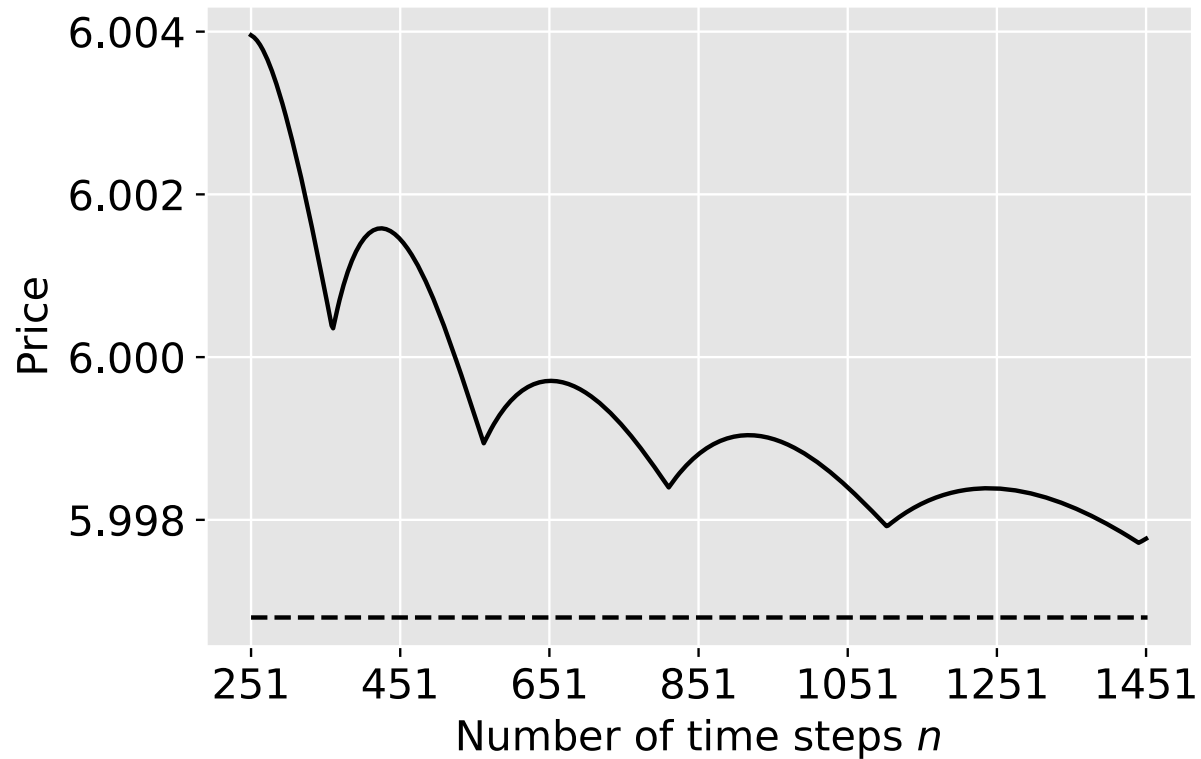

Plot of convergence of a down-and-out call to 5.9968 supplied by Mr. Lu, Yu-Ming (R06723032, D08922008) on February 26. 2021.

The Barrier-Too-Close Problem Revisited (concluded)

- The earlier trinomial tree is impractical as it needs a very large n when the barrier H is very close to S .^a
 - It needs at least one *up* move to connect S to H as its middle branch is flat.
 - But when $S \approx H$, that up move must take a very small step, necessitating a small Δt .
- Our trinomial structure's middle branch is *not* necessarily flat.
- So S can be connected to H via the middle branch, and the need of a very large n no longer exists!

^aRecall the table on p. 729.

Pricing Discrete and Moving Barrier Options

- Barrier options whose barrier is monitored only at discrete times are called discrete barrier options.
- They are less common than the continuously monitored versions for single stocks.^a
- The main difficulty with pricing discrete barrier options lies in matching the monitored *times*.
- Here is why.

^aBennett (2014).

Pricing Discrete and Moving Barrier Options (continued)

- Suppose each period has a duration of Δt and the $\ell > 1$ monitored times are

$$t_0 = 0, t_1, t_2, \dots, t_\ell = T.$$

- It is unlikely that *all* monitored times coincide with the end of a period on the tree, or Δt divides t_i for all i .
- The binomial-trinomial tree can handle discrete options with ease, however.
- Simply build a binomial-trinomial tree from time 0 to time t_1 , followed by one from time t_1 to time t_2 , and so on until time t_ℓ .

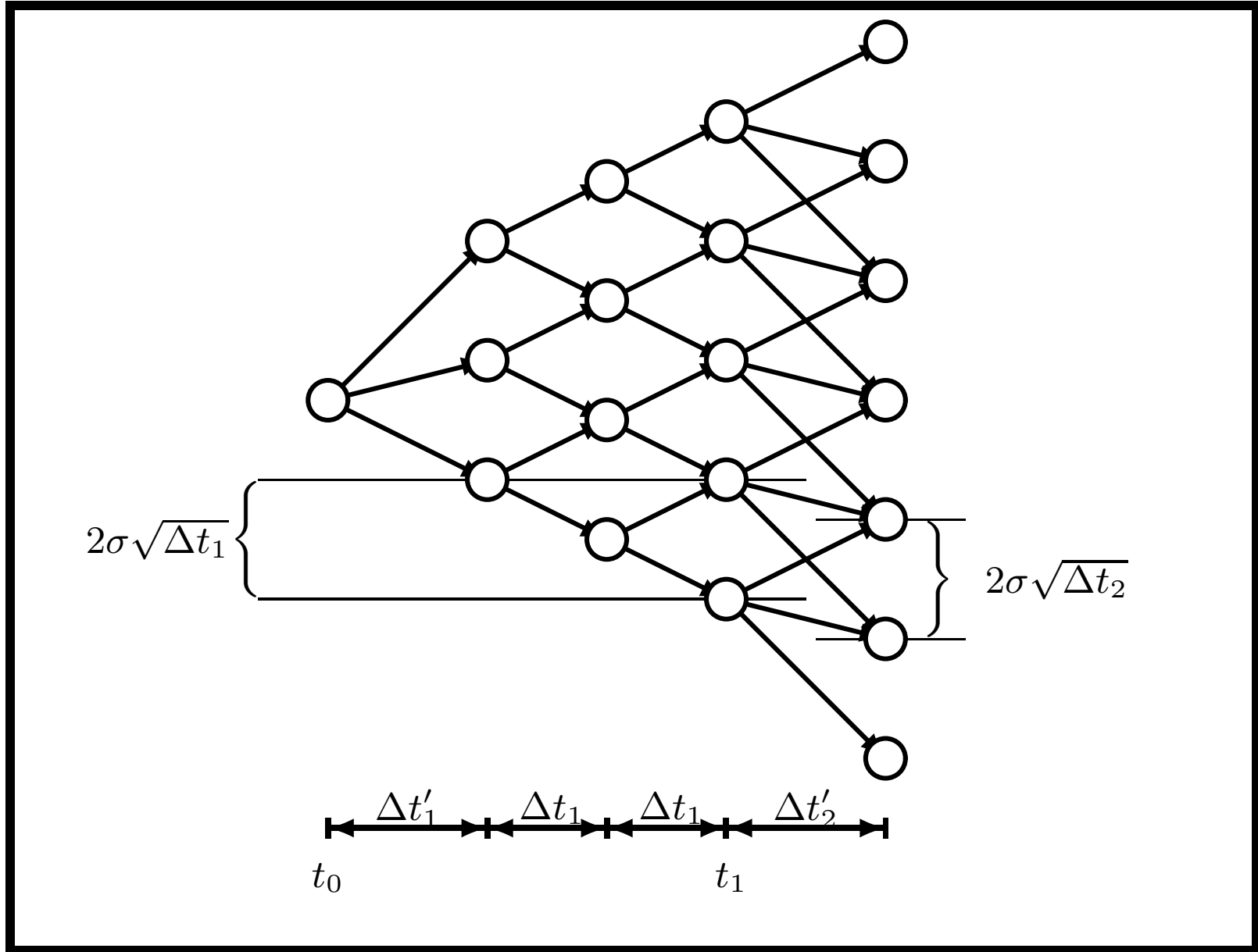

Pricing Discrete and Moving Barrier Options (concluded)

- This procedure works even if each t_i is associated with a distinct barrier or if each window $[t_i, t_{i+1})$ has its own continuously monitored barrier or double barriers.
- Pricing in both scenarios can actually be done in time $O[\ell n \ln(n/\ell)]$.^a
- For typical discrete barriers, placing barriers midway between two price levels on the tree may increase accuracy.^b

^aY. Lu (R06723032, D08922008) (2021).

^bSteiner & Wallmeier (1999); Tavella & Randall (2000).

Options on a Stock That Pays Known Dividends

- Many ad hoc assumptions have been postulated for option pricing with known dividends.^a
 1. The one we saw earlier^b models the stock price minus the present value of the anticipated dividends as following geometric Brownian motion.
 2. One can also model the stock price plus the forward values of the dividends as following geometric Brownian motion.

^aFrishling (2002).

^bOn p. 321.

Options on a Stock That Pays Known Dividends (continued)

- Realistic models assume:
 - The stock price decreases by the amount of the dividend paid at the ex-dividend date.
 - The dividend is part cash and part yield (i.e., $\alpha(t)S_0 + \beta(t)S_t$), for practitioners.^a
- The stock price follows geometric Brownian motion between adjacent ex-dividend dates.
- But they result in exponential-sized binomial trees.^b
- The binomial-trinomial tree can avoid this problem in most cases.

^aHenry-Labordère (2009).

^bRecall p. 320.

Options on a Stock That Pays Known Dividends (continued)

- Suppose that the known dividend is D dollars and the ex-dividend date is at time t .
- So there are $m \triangleq t/\Delta t$ periods between time 0 and the ex-dividend date.^a
- To avoid negative stock prices, we need to make sure the lowest stock price at time t is at least D , i.e.,

$$S e^{-(t/\Delta t)\sigma\sqrt{\Delta t}} \geq D.$$

– Or,

$$\Delta t \geq \left[\frac{t\sigma}{\ln(S/D)} \right]^2.$$

^aThat is, m is an integer input and $\Delta t \triangleq t/m$.

Options on a Stock That Pays Known Dividends (continued)

- Build a CRR tree from time 0 to time t as before.
- Subtract D from all the stock prices on the tree at time t to represent the price drop on the ex-dividend date.
- Assume the top node's price equals S' .
 - As usual, its two successor nodes will have prices $S'u$ and $S'u^{-1}$.
- The remaining nodes' successor nodes at time $t + \Delta t$ will choose from prices

$$S'u, S', S'u^{-1}, S'u^{-2}, S'u^{-3}, \dots,$$

same as the CRR tree.

A Stair Tree

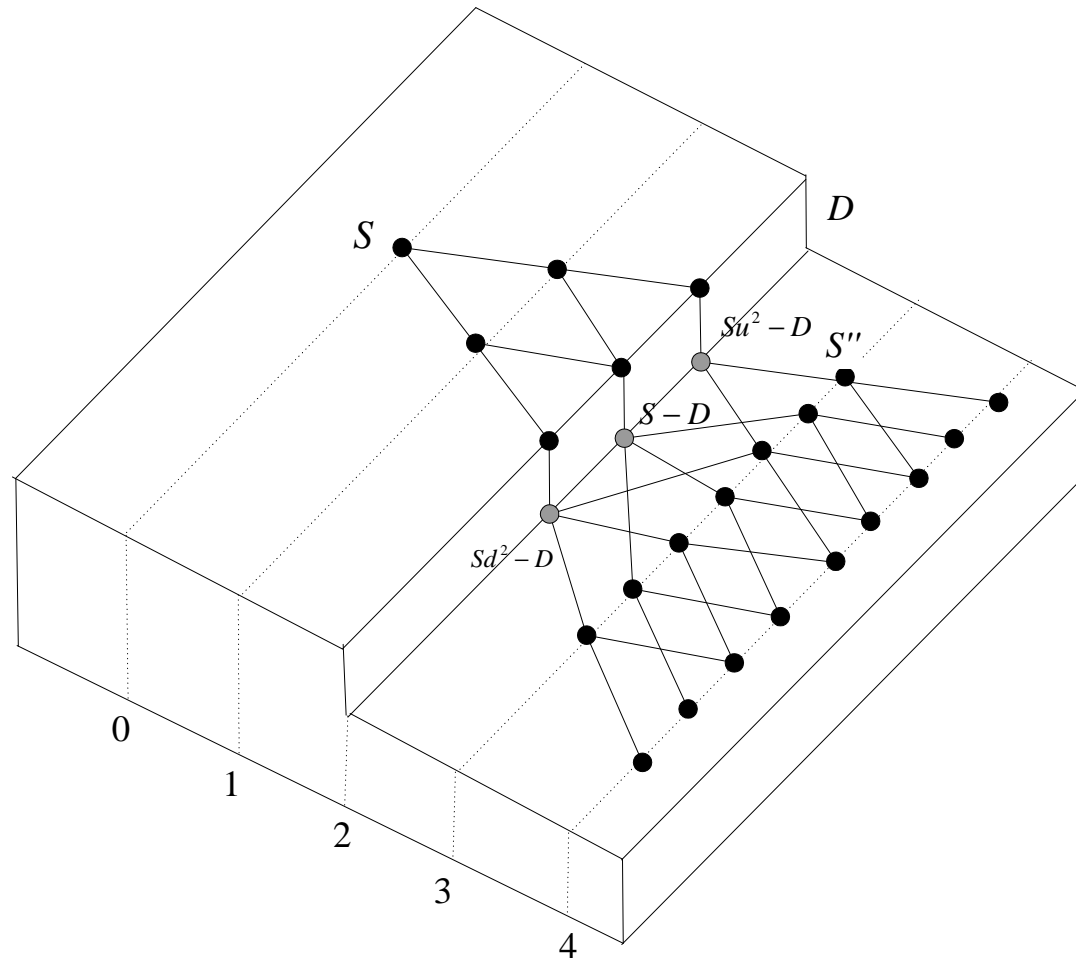

Options on a Stock That Pays Known Dividends (continued)

- For each node at time t below the top node, we build the trinomial connection.
- Note that the binomial-trinomial structure remains valid in the special case when $\Delta t' = \Delta t$ on p. 755.

Options on a Stock That Pays Known Dividends (concluded)

- Hence the construction can be completed.
- From time $t + \Delta t$ onward, the standard binomial tree will be used until the maturity date or the next ex-dividend date when the procedure can be repeated.
- The resulting tree is called the stair tree.^a

^aDai (B82506025, R86526008, D8852600) & Lyuu (2004); Dai (B82506025, R86526008, D8852600) (2009).

Other Applications of Binomial-Trinomial Trees

- Pricing guaranteed minimum withdrawal benefits.^a
- Option pricing with stochastic volatilities.^b
- Efficient Parisian option pricing.^c
- Option pricing with time-varying volatilities and time-varying double barriers of an exponential form.^d
- Defaultable bond pricing.^e

^aH. Wu (R96723058) (2009).

^bC. Huang (R97922073) (2010).

^cY. Huang (R97922081) (2010).

^dC. Chou (R97944012) (2010); C. I. Chen (R98922127) (2011).

^eDai (B82506025, R86526008, D8852600), Lyuu, & C. Wang (F95922018) (2009, 2010, 2014).

Mean Tracking^a

- The general idea behind the binomial-trinomial tree on pp. 754ff is very powerful.
- One finds the successor middle node as the one closest to the mean.
- The two flanking successor nodes are then spaced at $c\sigma\sqrt{\Delta t}$ from the middle node for a suitably large $c > 0$.
- The resulting trinomial structure are then guaranteed to have valid branching probabilities.

^aLyuu & C. Wu (R90723065) (2003, 2005).

Default Boundary as Implied Barrier

- Under the structural model,^a the default boundary is modeled as a barrier.^b
- The constant barrier can be inferred from the closed-form formula given the firm's market capitalization, etc.^c
- More generally, the moving barrier can be inferred from the term structure of default probabilities with the binomial-trinomial tree.^d

^aRecall p. 369.

^bBlack & Cox (1976).

^cBrockman & Turtle (2003).

^dY. Lu (R06723032, D08922008) (2019).

Default Boundary as Implied Barrier (concluded)

- This barrier is called the implied barrier.^a
- If the barrier is a step function,^b the implied barrier can be obtained in $O(n \ln n)$ time.^c
- The next plot shows the implied barriers of Freddie Mac and Fannie Mae as of February 2008 (as percentages of initial asset values).^d

^aBrockman & Turtle (2003).

^bThe option is then called a rolling option.

^cY. Lu (R06723032, D08922008) & Lyuu (2021).

^dPlot supplied by Mr. Lu, Yu-Ming (R06723032, D08922008) on February 26, 2021.

