

Traffic-Aware Beam Selection and Resource Allocation for 5G NR

Yu-Hsuan Liu and Kate Lin

National Chiao Tung University, Taiwan



5G NR: Massive MIMO and Beamforming

- **Analog beamforming**

- ▶ Phased array antennas that maximize the energy of a direction

- **Hybrid beamforming**

- ▶ Connect each RF chain to a phased array to steer the beam
- ▶ Select N beams from available beams to serve N UEs

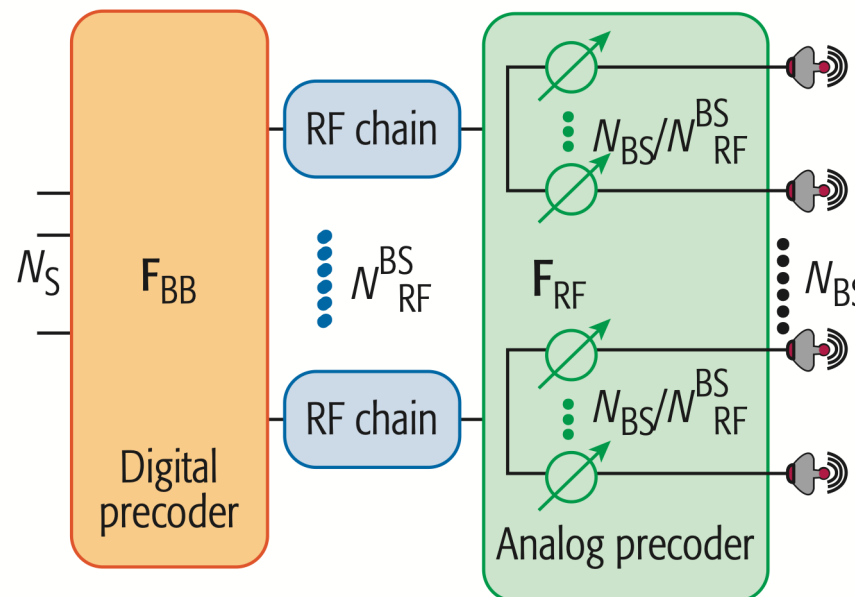

Inter-Beam Interference

- **Side lobes**
 - ▶ energy could be leaked toward an undesired direction
- **Inter-beam interference**
 - ▶ The side-lobes of a beam could interfere with the main-lobes of another beam

Explicitly consider inter-beam interference in beam selection

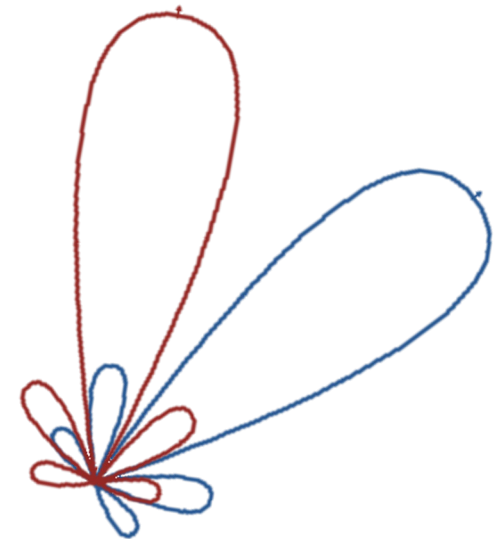

Beam Configuration for OFDMA

- 5G adopts OFDMA to allocate resource blocks
- A subset of beams are configured in a time-slot
 - ▶ *All subcarriers share the same beams*

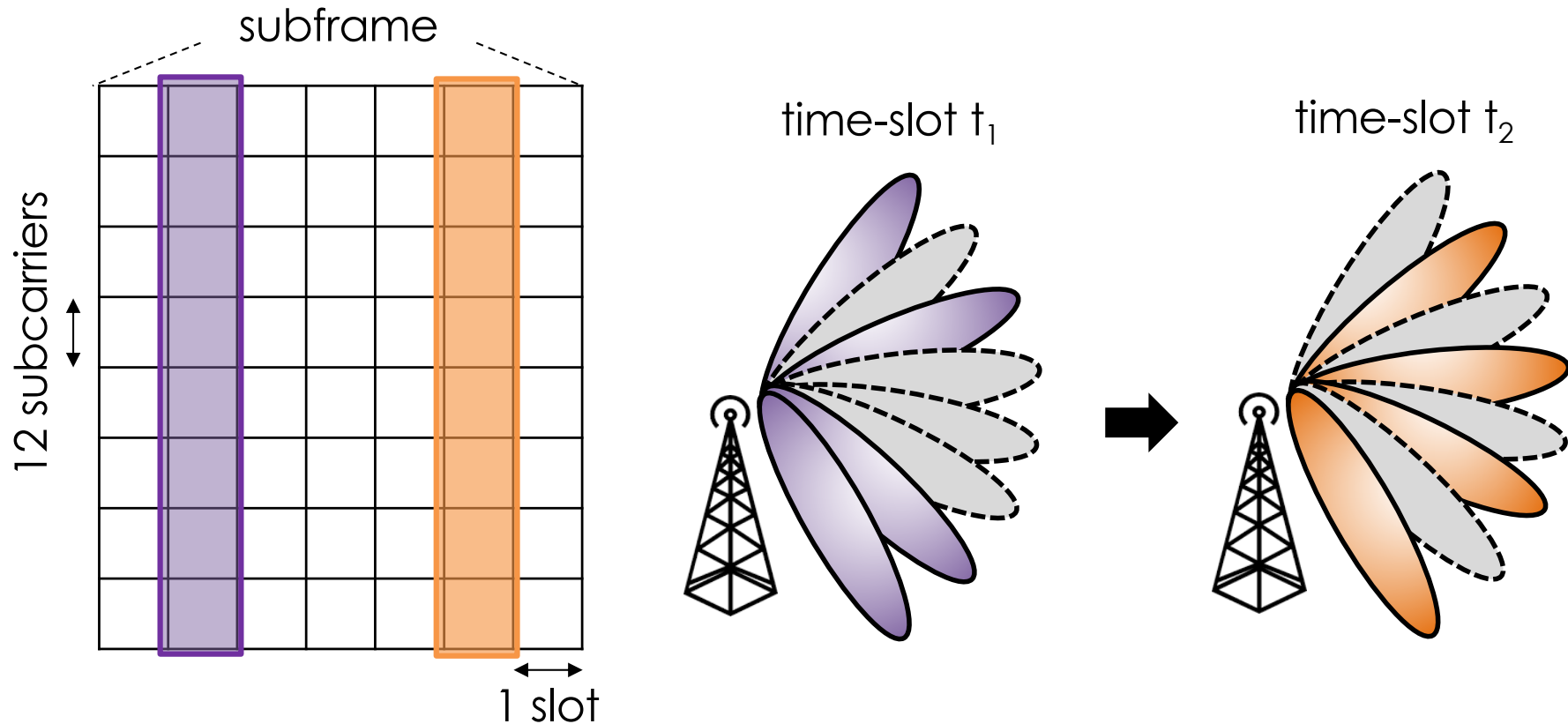

Efficiency of Beam Configuration

- Existing solutions maximize the sum-rate or minimize inter-beam interference

- RBs not fully utilized due to low demands

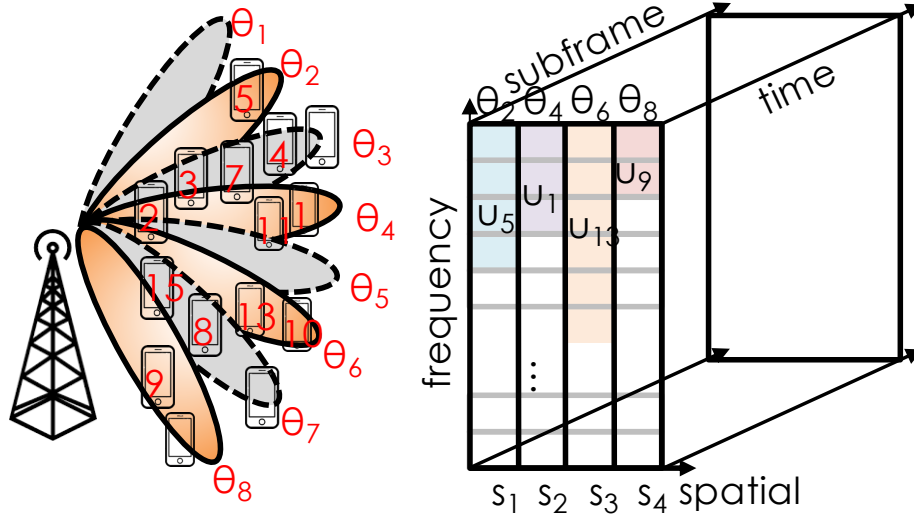

- RBs fully utilized, though slightly lower rate

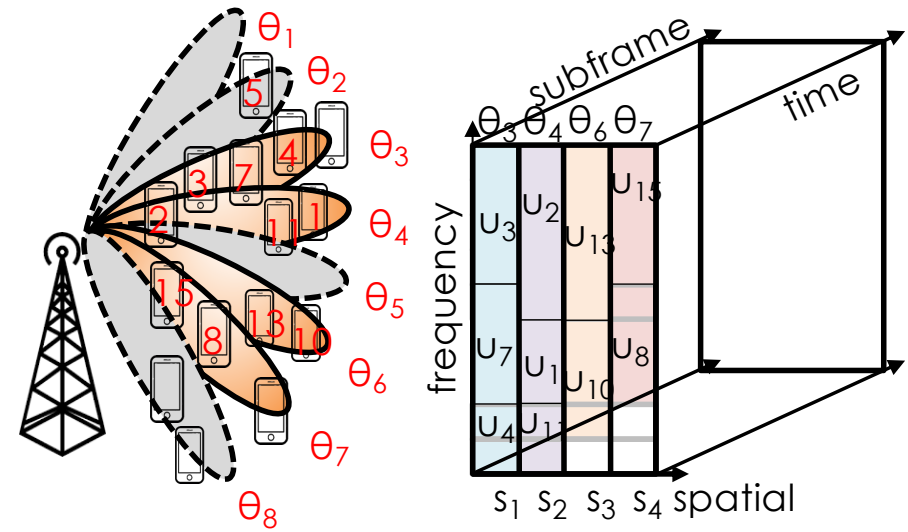

Beam configuration should jointly consider inter-beam interference and demands

Existing Solutions

- Beam configuration for **rate maximization**
 - ▶ consider the distance of UEs and develop an interference cancellation scheme [Lin-TCOM-15]
 - ▶ minimize the interference among concurrent users [Gao-COMML-16]
 - ▶ exploit two-stage capacity maximization to reduce the complexity of beam searching [Nair-ICC-18]
- Our work jointly considers the **OFDMA property** and **user traffic demands**

1. C. Lin and G. Y. Li.2015. "Adaptive beamforming with resource allocation for distance-aware multi-user indoor terahertz communications." In IEEE TCOM.
2. X. Gao, L. Dai, Z. Chen, Z. Wang, and Z. Zhang.2016. "Near-optimal beam selection for beamspace mmWave massive MIMO systems." In IEEE COMML.
3. J. P. Nair, R. K. Guha, A. Guchhait, P. S. C. Thejaswi, S. Amuru, V. Prakash, and D. Lee.2018. "Capacity based efficient beam-selection methods for mmWave 5G MIMO communication systems." In IEEE ICC.

Outline

- Problem Statement
- Proposed Algorithms
- Performance Evaluation
- Conclusion

Problem Statement

- **Task**

- ▶ Jointly select a subset of beams and allocate resource blocks to UEs

- **Decision variables**

- ▶ $X_{t,\theta}$: binary variable indicating whether beam θ is used at time-slot t
- ▶ $Y_{u,t,f,\theta}$: binary variable indicating whether to schedule UE u in RB (t, f) belonging to beam θ

- **Objective**

- ▶ Maximize long-term effective throughput

$$\max \sum_{u \in V} r_u = \sum_{u \in V} \frac{l_u}{\delta |T|}$$

System Model

- Constraints

$$\sum_{\theta \in \Theta} I_{t,\theta} \leq N, \forall t \in T$$

Number of beams

$$\sum_{u \in V} J_{u,t,f,\theta} \leq I_{t,\theta}, \forall f \in F, t \in T, \theta \in \Theta$$

RB-beam association

$$l_u \leq \sum_{f \in F, t \in T} \delta W \log_2 \left(1 + \frac{J_{u,t,f,\theta} P_{u,\theta}}{\sum_{u' \in V, \theta' \neq \theta} J_{u',t,f,\theta'} P_{u,\theta'}} \right), \forall u \in V$$

Sum capacity

$$l_u \leq d_u, \forall u \in V$$

Traffic demand

Parameter	Meaning
\mathcal{V}	set of UEs
Θ	set of available beams
F	set of subcarriers
T	set of time-slots
N	maximum number of streams
W	bandwidth of a subcarrier
δ	time interval of a slot
d_u	traffic demand for UE u
λ_u	receiving power of UE u from best beam

Greedy Algorithms

- **Maximal-demand allocation**

1. Each UE associates with its optimal beams
2. Sort beams in descending order of the demands of the associated UEs
3. Select the first **N** beams

- **Top-K demand allocation**

1. Same as steps 1-2
2. Identify the first **K** beams ($K > N$)
3. Select **N** beams producing the maximal sum-rate

Maximal-Demand Allocation

- Select beams with the maximal demands
- Neglect the impact of users' achievable SINR

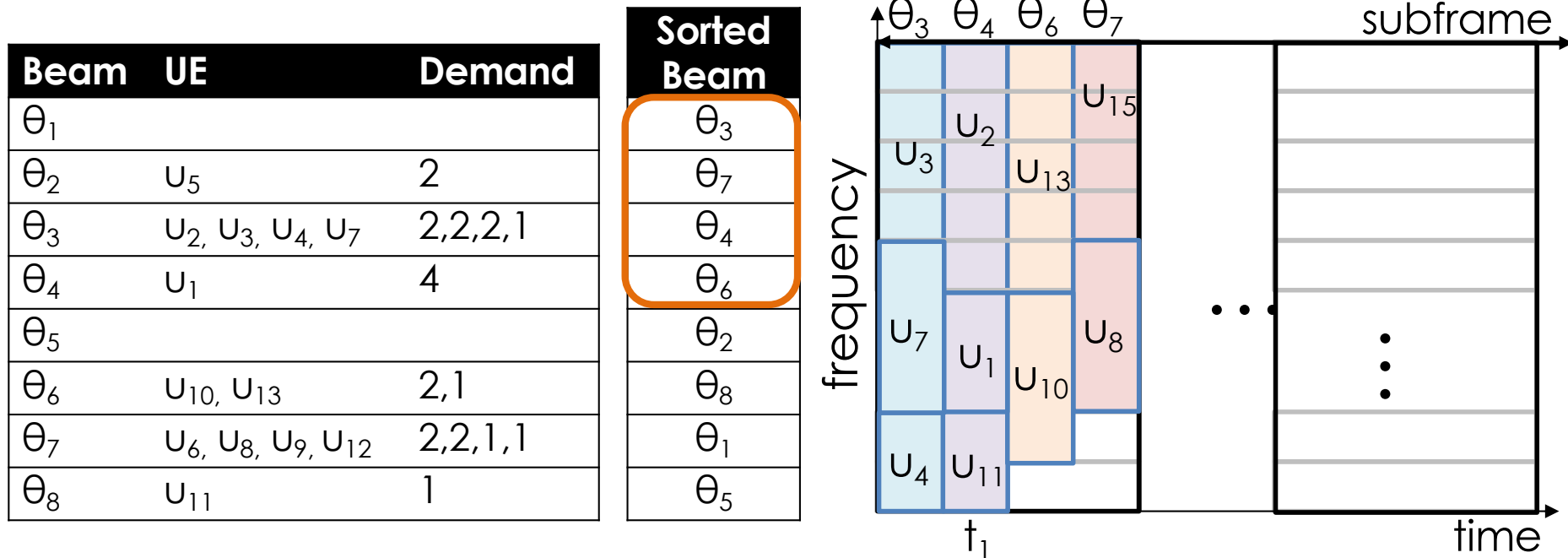

Traffic-aware RB allocation

Inter-beam interference could be large

Top-K Demand Allocation

- Select beams with **top-K** demands
- Pick **N** that maximize the sum-rate

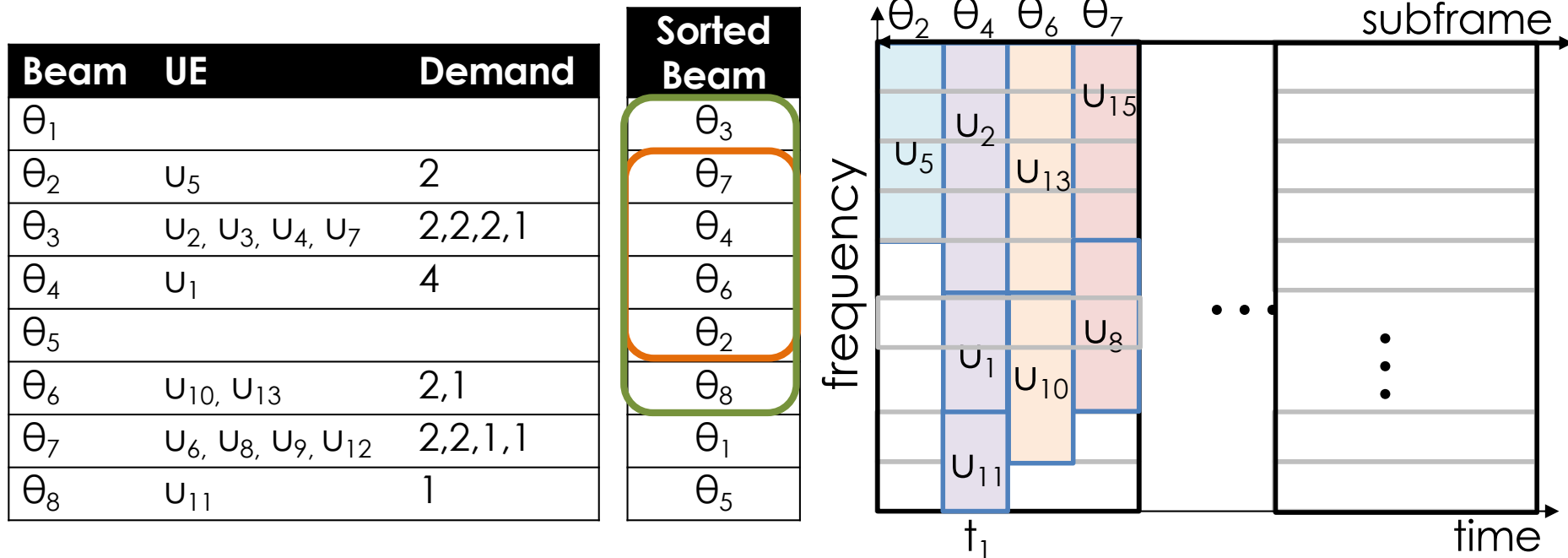

Traffic-aware allocation with consideration of interference

Jointly consider demands and achievable rate

Utilization Enhancement

- Enhance resource utilization by allocating the **unused RBs**
- Allocating unused RBs to **non-associated UEs** if non-associated UEs
 - ▶ can obtain non-negative rates
 - ▶ Still have demands

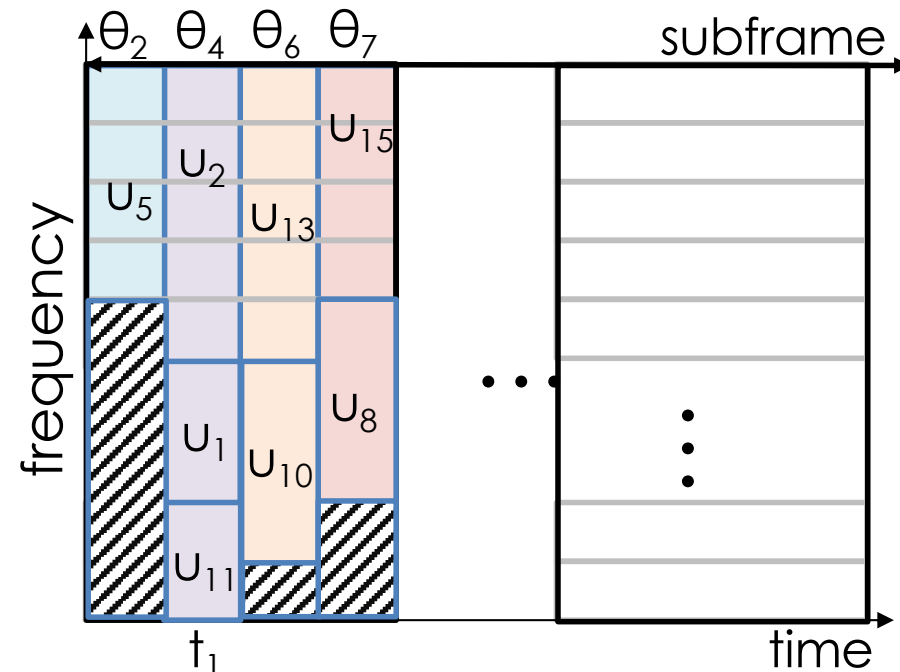

Performance Evaluation

Simulation Settings

- The traffic arrival pattern of UE u follows the Poisson distribution with arrival rate λ_u
- The mean arrival rates follow the Zipf's law with skewness α

Parameter	Value
$ F $	100
$ T $	20
$ \Theta $	8
$ \mathcal{V} $	{20,40,60,80,100}
N	4
W	180kHz
δ	0.5ms
N_0	-50dBm

Parameter	Value
packet size	1000 bits
d_u	based on arrival rate λ_u
λ_u	{0.2,0.4,0.6,0.8,1,1.2}
α	{0,0.3,0.6,0.9,1.2,1.5}
top-K	5
Distance	1~150m
Frequency	2110 MHz
$P_{u,\theta}$	Friss' path loss model

Impact of Number of UEs

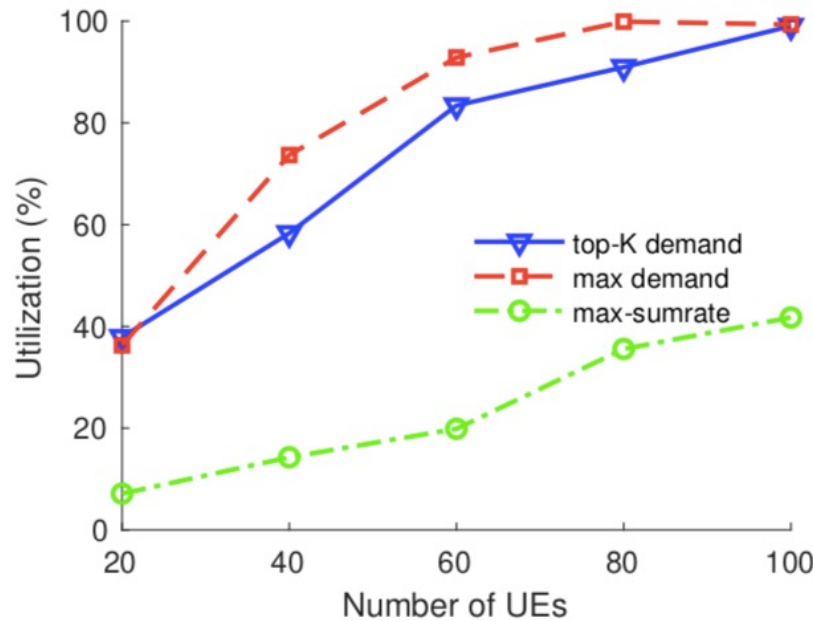

(a) Utilization

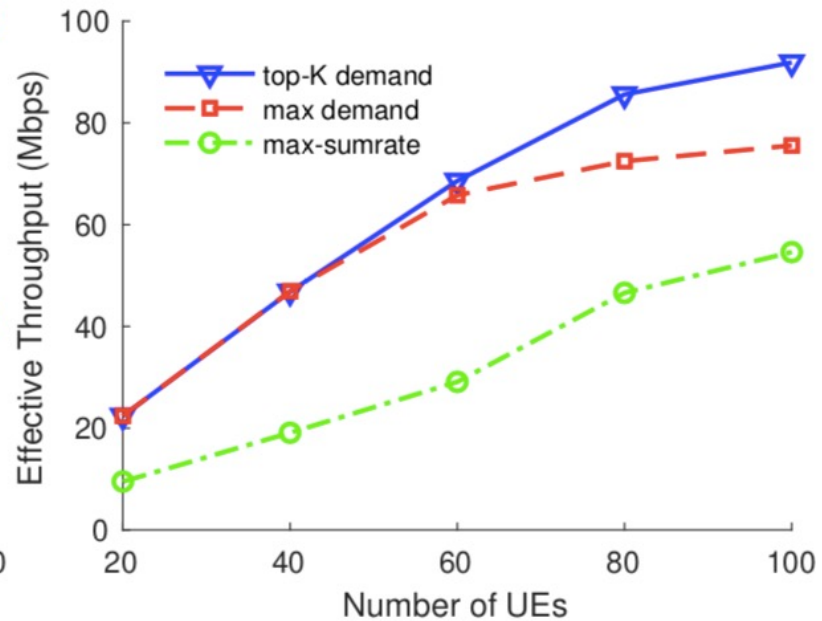

(b) Effective Throughput

- **Max-sumrate** does not consider user demands, under-utilizing the available resources
- The gap between **top-K demand** and **max-demand** grows when **the demands grow**

Impact of Traffic Demands

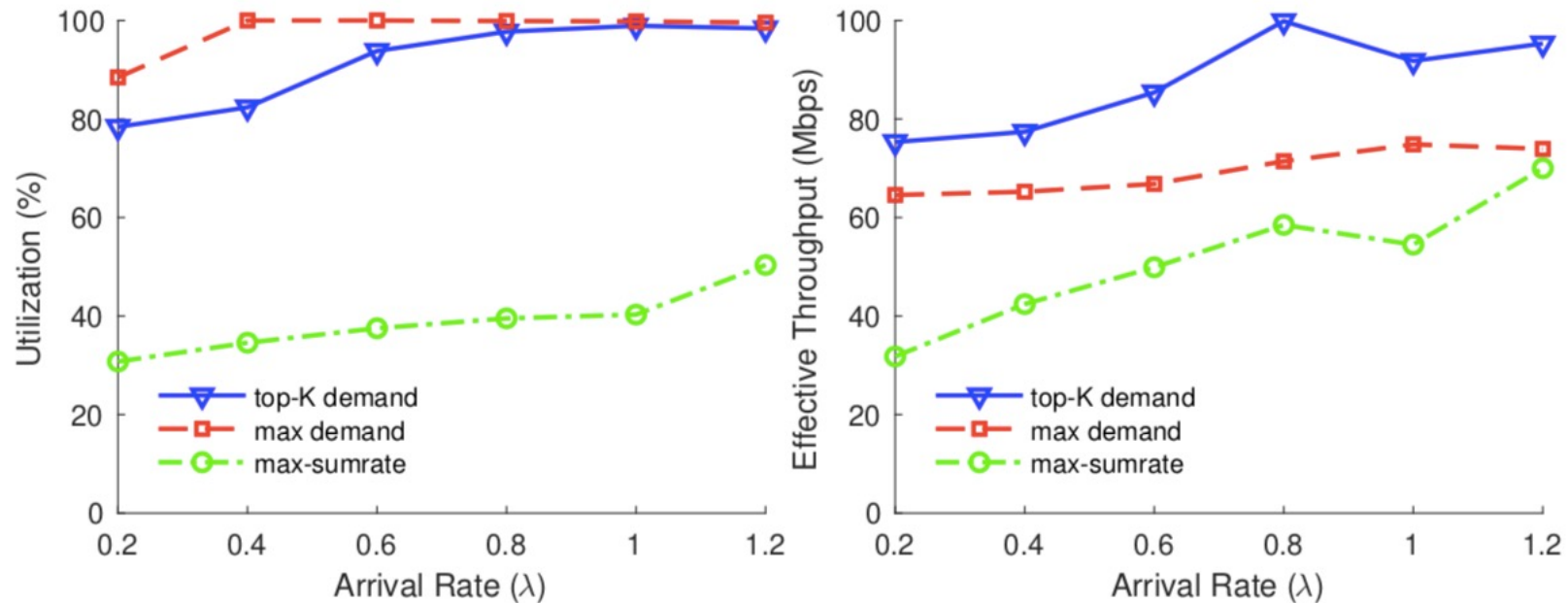

- When the resources are fully utilized, **top-K demand** considers the interference and can achieve a higher overall throughput

Impact of Demand Heterogeneity

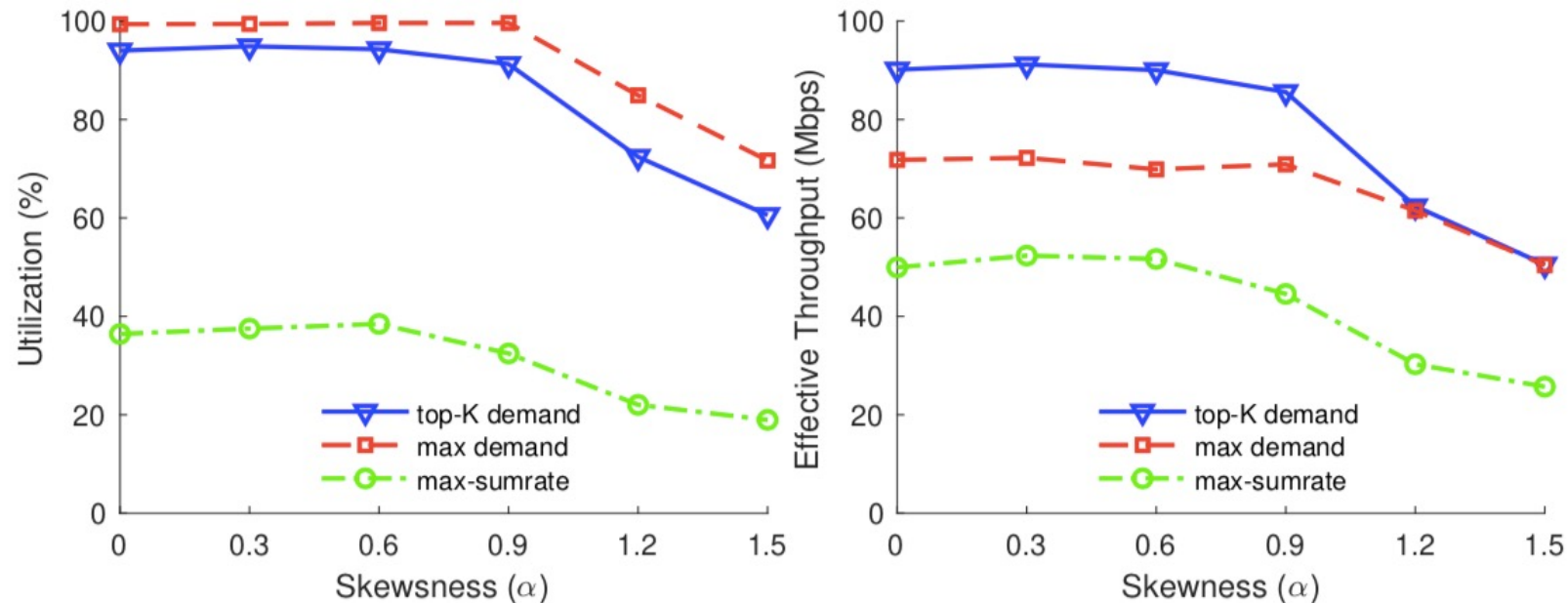

- Larger α , higher heterogeneity
- **Max-demand** works fine when α is large since it can identify the beam with max-demand
- **Top-K demand** performs better for homogeneous demands since it considers interference

Conclusion

- Proposed **traffic-aware** joint beam configuration and resource allocation
 - ▶ Enhance resource utilization
 - ▶ Jointly consider demands and inter-beam interference
- Enhanced utilization by allocating resources to secondary UEs
- Improved the overall throughput by **up to 2.37x**