

ARM Architecture

Computer Organization and Assembly Languages

Yung-Yu Chuang

2008/11/17

with slides by Peng-Sheng Chen, Ville Pietikainen

ARM history



- 1983 developed by Acorn computers
 - To replace 6502 in BBC computers
 - 4-man VLSI design team
 - Its simplicity comes from the inexperience team
 - Match the needs for generalized SoC for reasonable power, performance and die size
 - The first commercial RISC implementation
- 1990 ARM (Advanced RISC Machine), owned by Acorn, Apple and VLSI

Why ARM?



- One of the most licensed and thus widespread processor cores in the world
 - Used in PDA, cell phones, multimedia players, handheld game console, digital TV and cameras
 - ARM7: GBA, iPod
 - ARM9: NDS, PSP, Sony Ericsson, BenQ
 - ARM11: Apple iPhone, Nokia N93, N800
 - 75% of 32-bit embedded processors
- Used especially in portable devices due to its low power consumption and reasonable performance

ARM powered products

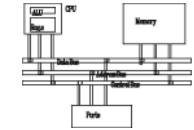

ARM processors



- A simple but powerful design
- A whole family of designs sharing similar design principles and a common instruction set

Naming ARM



- ARMxyzTDMIEJFS
 - x: series
 - y: MMU
 - z: cache
 - T: Thumb
 - D: debugger
 - M: Multiplier
 - I: EmbeddedICE (built-in debugger hardware)
 - E: Enhanced instruction
 - J: Jazelle (JVM)
 - F: Floating-point
 - S: Synthesizable version (source code version for EDA tools)

Popular ARM architectures



- ARM7TDMI
 - 3 pipeline stages (fetch/decode/execute)
 - High code density/low power consumption
 - One of the most used ARM-version (for low-end systems)
 - All ARM cores after ARM7TDMI include TDMI even if they do not include TDMI in their labels
- ARM9TDMI
 - Compatible with ARM7
 - 5 stages (fetch/decode/execute/memory/write)
 - Separate instruction and data cache
- ARM11

ARM family comparison

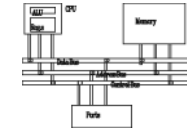

ARM family attribute comparison.

year	1995	1997	1999	2003
	ARM7	ARM9	ARM10	ARM11
Pipeline depth	three-stage	five-stage	six-stage	eight-stage
Typical MHz	80	150	260	335
mW/MHz ^a	0.06 mW/MHz	0.19 mW/MHz (+ cache)	0.5 mW/MHz (+ cache)	0.4 mW/MHz (+ cache)
MIPS ^b /MHz	0.97	1.1	1.3	1.2
Architecture	Von Neumann	Harvard	Harvard	Harvard
Multiplier	8 × 32	8 × 32	16 × 32	16 × 32

^a Watts/MHz on the same 0.13 micron process.

^b MIPS are Dhrystone VAX MIPS.

ARM is a RISC



- RISC: simple but powerful instructions that execute within a single cycle at high clock speed.
- Four major design rules:
 - Instructions: reduced set/single cycle/fixed length
 - Pipeline: decode in one stage/no need for microcode
 - Registers: a large set of general-purpose registers
 - Load/store architecture: data processing instructions apply to registers only; load/store to transfer data from memory
- Results in simple design and fast clock rate
- The distinction blurs because CISC implements RISC concepts

ARM design philosophy



- Small processor for lower power consumption (for embedded system)
- High code density for limited memory and physical size restrictions
- The ability to use slow and low-cost memory
- Reduced die size for reducing manufacture cost and accommodating more peripherals

ARM features



- Different from pure RISC in several ways:
 - Variable cycle execution for certain instructions: multiple-register load/store (faster/higher code density)
 - Inline barrel shifter leading to more complex instructions: improves performance and code density
 - Thumb 16-bit instruction set: 30% code density improvement
 - Conditional execution: improve performance and code density by reducing branch
 - Enhanced instructions: DSP instructions

ARM architecture

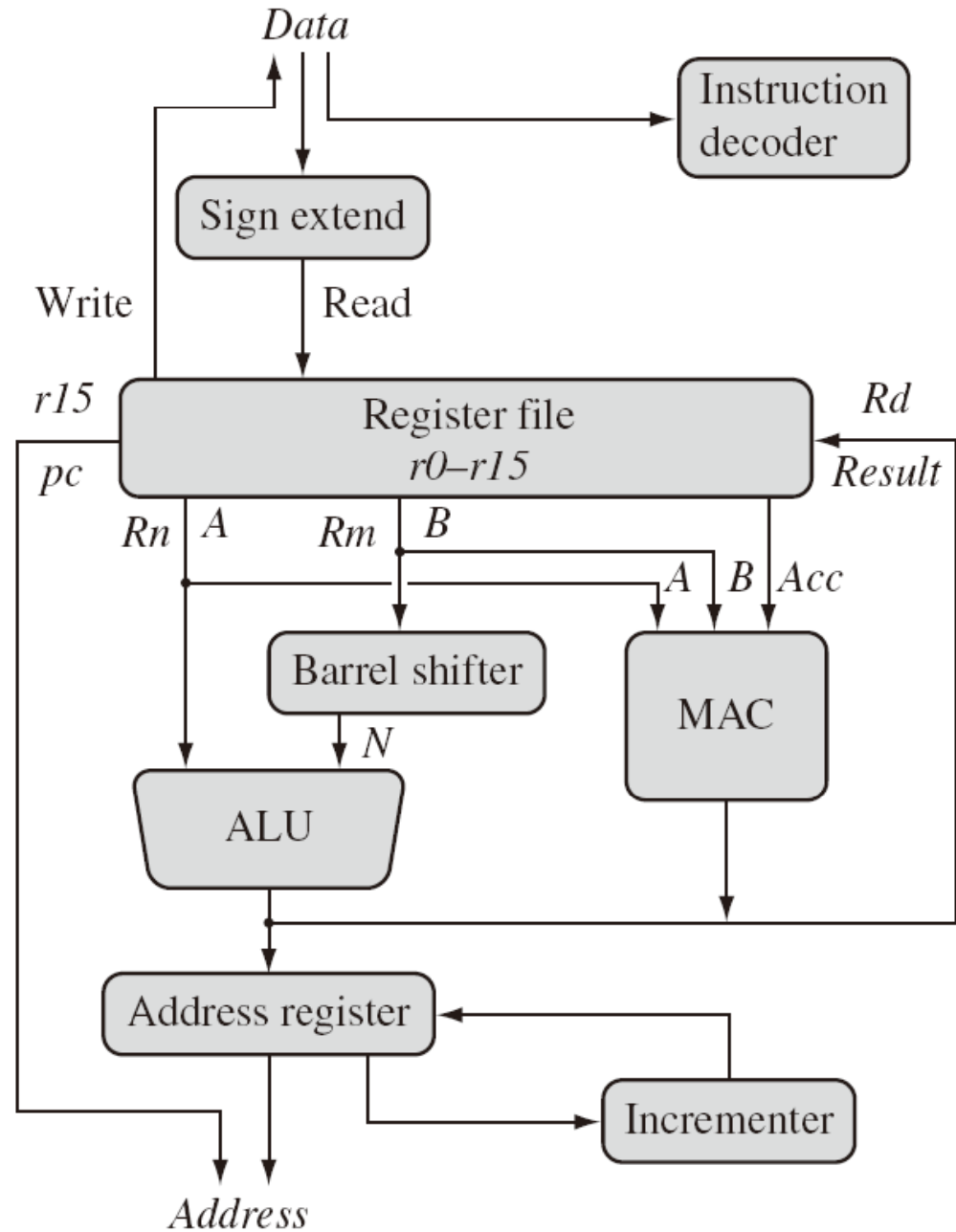

ARM architecture

- Load/store architecture
- A large array of uniform registers
- Fixed-length 32-bit instructions
- 3-address instructions

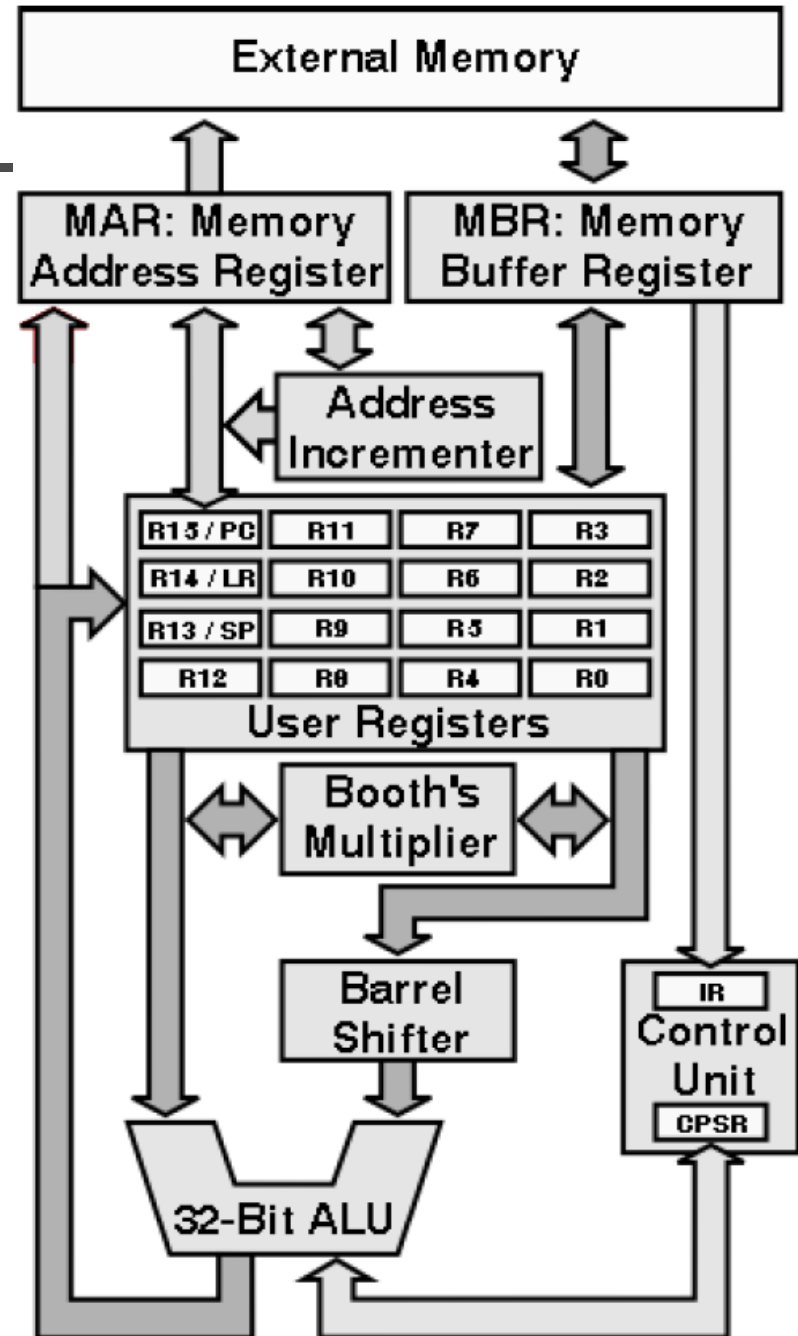

Registers



- Only 16 registers are visible to a specific mode.
A mode could access
 - A particular set of r0-r12
 - r13 (sp, stack pointer)
 - r14 (lr, link register)
 - r15 (pc, program counter)
 - Current program status register (cpsr)
 - The uses of r0-r13 are orthogonal

General-purpose registers

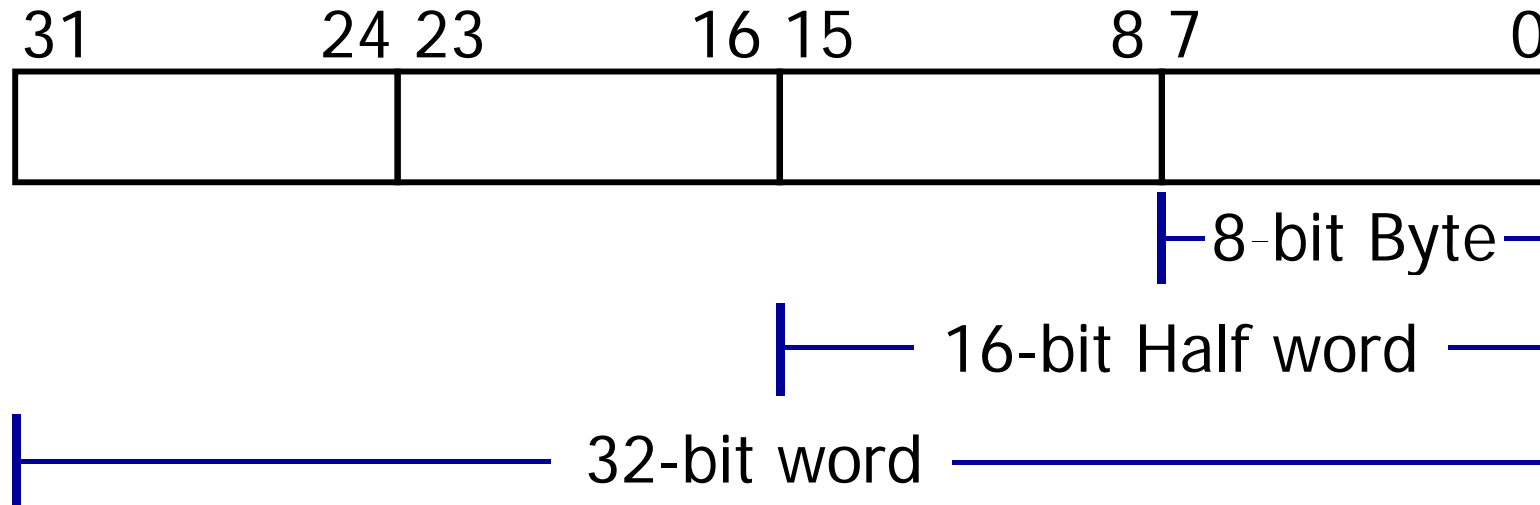

- 6 data types (signed/unsigned)
- All ARM operations are 32-bit. Shorter data types are only supported by data transfer operations.

Program counter

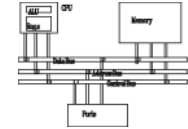

- Store the address of the instruction to be executed
- All instructions are 32-bit wide and word-aligned
- Thus, the last two bits of pc are undefined.

Program status register (CPSR)

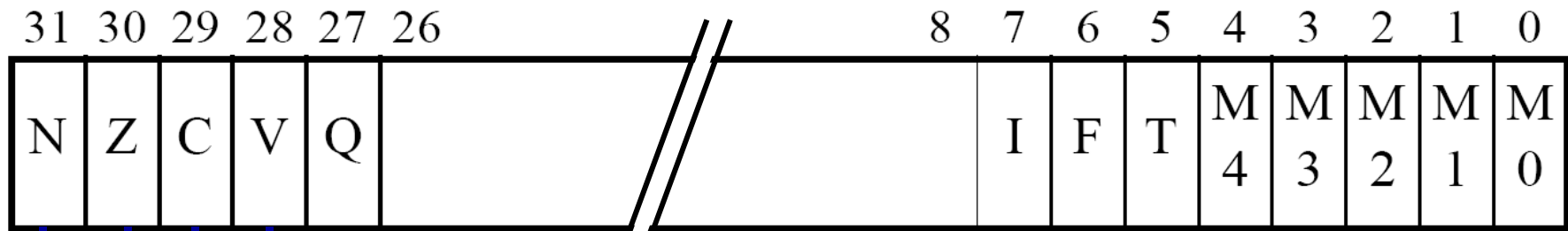
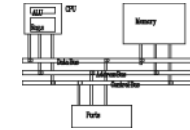

negative
zero
carry/borrow
overflow

mode bits
Thumb state
FIQ disable
IRQ disable

Processor modes

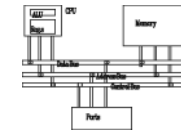

Processor mode		Description
User	usr	Normal program execution mode
FIQ	fiq	Supports a high-speed data transfer or channel process
IRQ	irq	Used for general-purpose interrupt handling
Supervisor	svc	A protected mode for the operating system
Abort	abt	Implements virtual memory and/or memory protection
Undefined	und	Supports software emulation of hardware coprocessors
System	sys	Runs privileged operating system tasks

Register organization

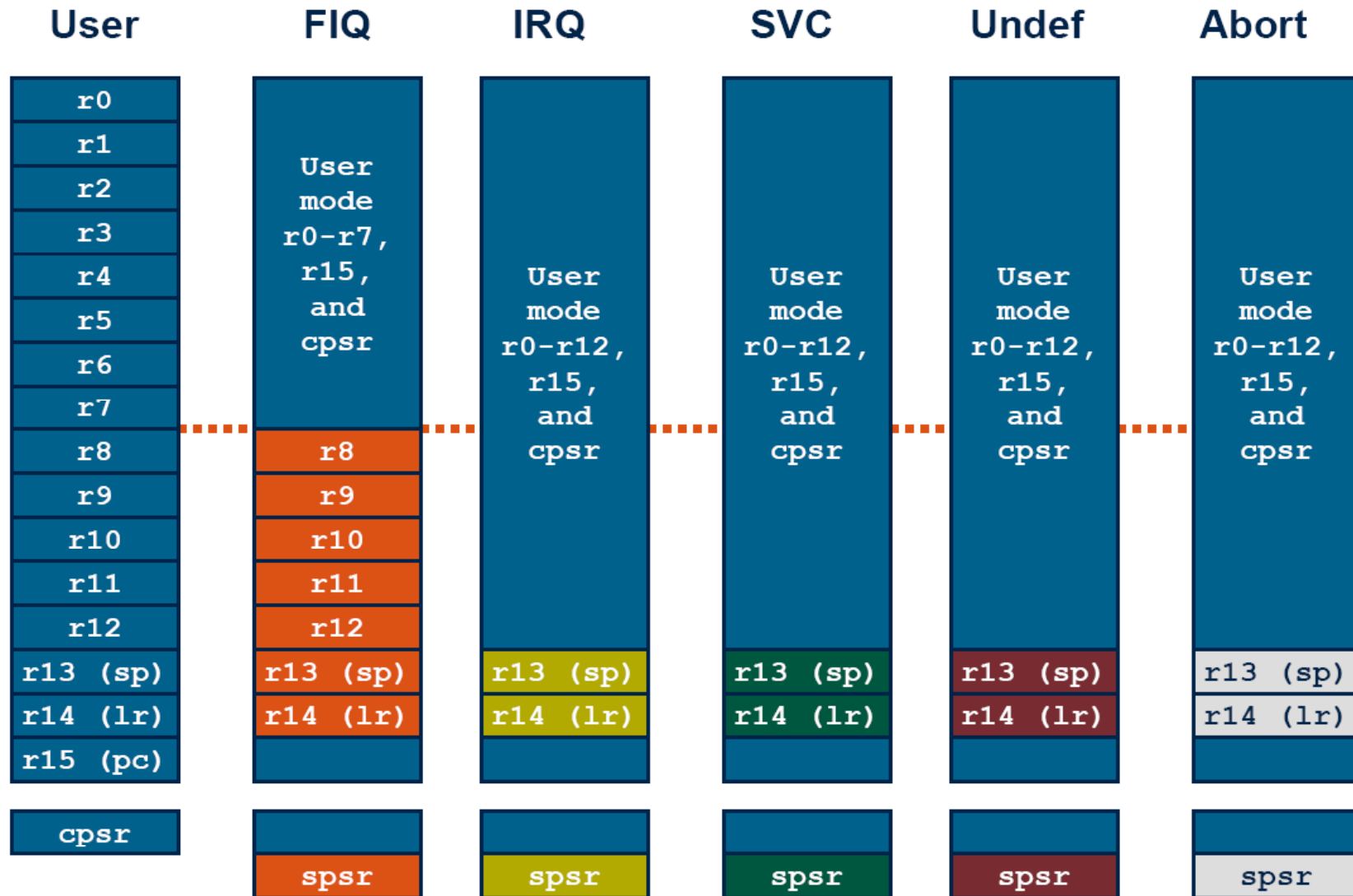
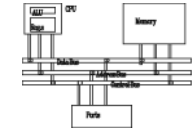

Instruction sets

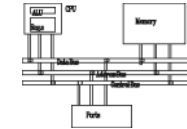

- ARM/Thumb/Jazelle

	ARM (<i>cpsr</i> $T = 0$)	Thumb (<i>cpsr</i> $T = 1$)
Instruction size	32-bit	16-bit
Core instructions	58	30
Conditional execution ^a	most	only branch instructions
Data processing instructions	access to barrel shifter and ALU	separate barrel shifter and ALU instructions
Program status register	read-write in privileged mode	no direct access
Register usage	15 general-purpose registers + <i>pc</i>	8 general-purpose registers + 7 high registers + <i>pc</i>
Jazelle (<i>cpsr</i> $T = 0, J = 1$)		
Instruction size	8-bit	
Core instructions	Over 60% of the Java bytecodes are implemented in hardware; the rest of the codes are implemented in software.	

Pipeline

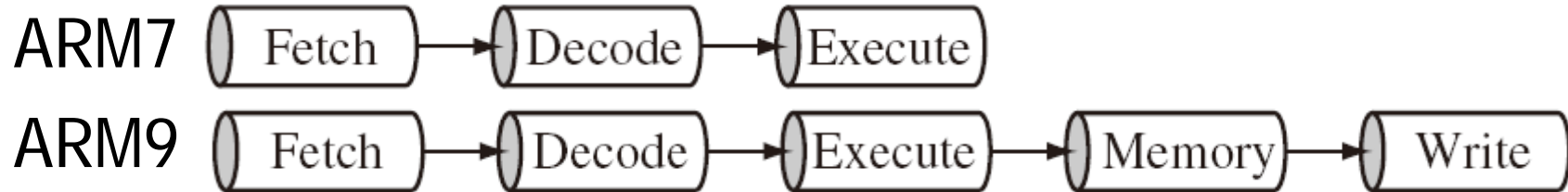

In execution, pc always 8 bytes ahead

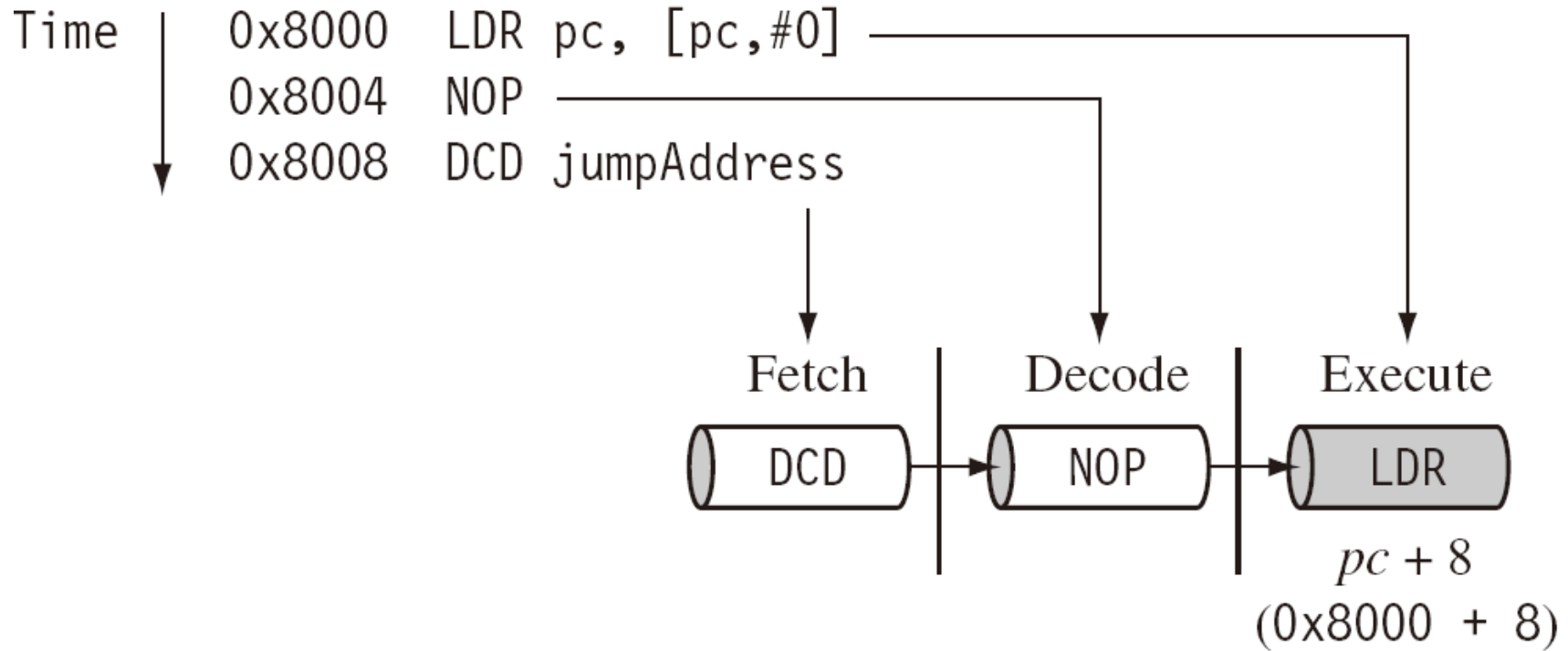

Pipeline

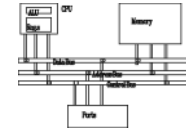

- Execution of a branch or direct modification of pc causes ARM core to flush its pipeline
- ARM10 starts to use branch prediction
- An instruction in the execution stage will complete even though an interrupt has been raised. Other instructions in the pipeline are abandoned.

Interrupts

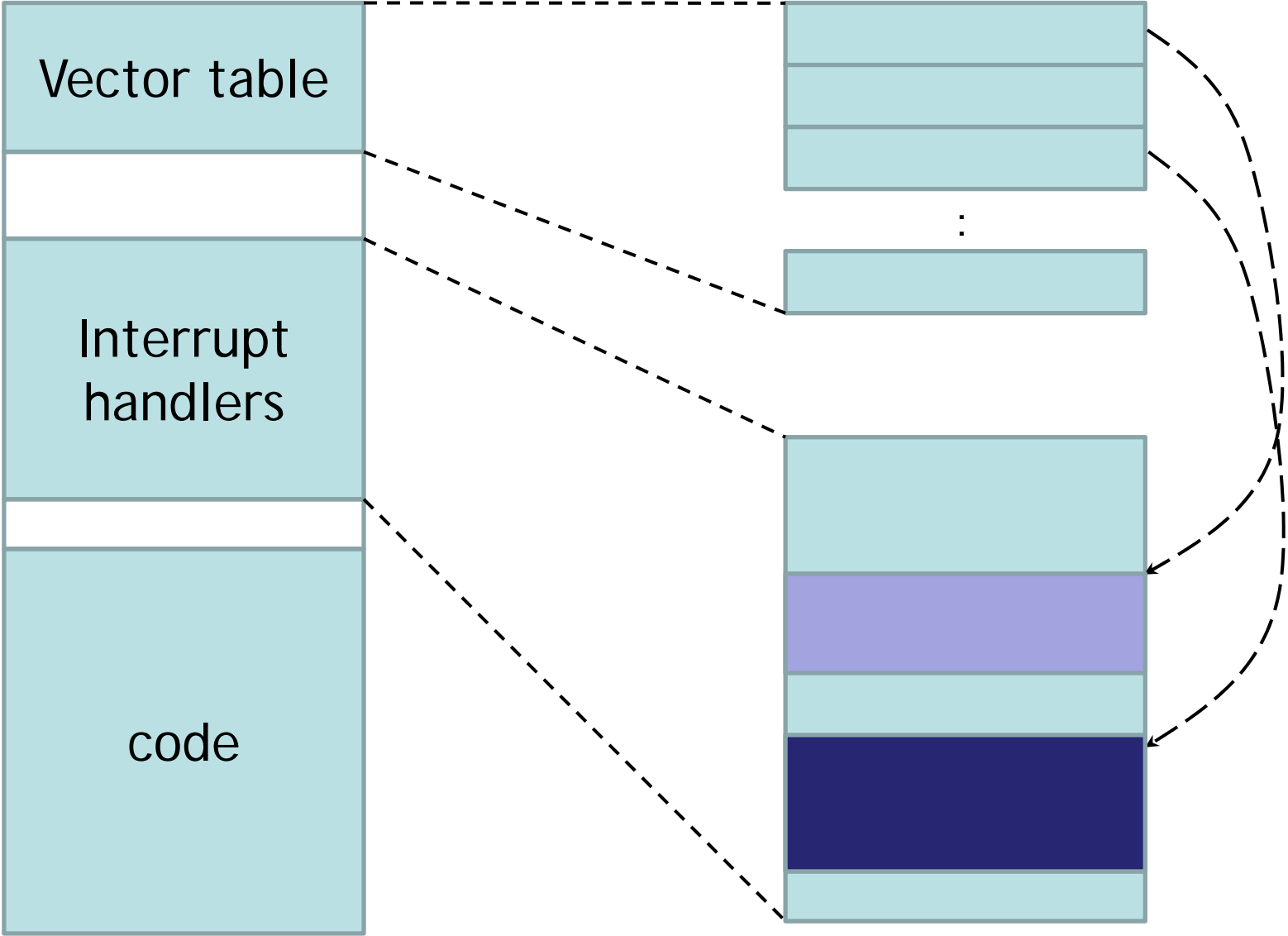

Interrupts

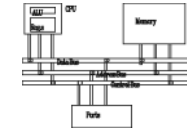

Exception/interrupt	Shorthand	Address
Reset	RESET	0x00000000
Undefined instruction	UNDEF	0x00000004
Software interrupt	SWI	0x00000008
Prefetch abort	PABT	0x0000000c
Data abort	DABT	0x00000010
Reserved	—	0x00000014
Interrupt request	IRQ	0x00000018
Fast interrupt request	FIQ	0x0000001c
