



Computer Organization & Assembly Languages

Conditional Processing

Pu-Jen Cheng

Adapted from the slides prepared by Kip Irvine for the book,
Assembly Language for Intel-Based Computers, 5th Ed.



Chapter Overview

- **Boolean and Comparison Instructions**
- Conditional Jumps
- Conditional Loop Instructions
- Conditional Structures
- Application: Finite-State Machines
- Decision Directives



Boolean and Comparison Instructions

- CPU Status Flags
- AND Instruction
- OR Instruction
- XOR Instruction
- NOT Instruction
- Applications
- TEST Instruction
- CMP Instruction



Status Flags - Review

- The **Zero** flag is set when the result of an operation equals zero.
- The **Carry** flag is set when an instruction generates a result that is too large (or too small) for the destination operand.
- The **Sign** flag is set if the destination operand is negative, and it is clear if the destination operand is positive.
- The **Overflow** flag is set when an instruction generates an invalid signed result.
- The **Parity** flag is set when an instruction generates an even number of 1 bits in the low byte of the destination operand.
- The **Auxiliary Carry** flag is set when an operation produces a carry out from bit 3 to bit 4

AND Instruction

- Performs a Boolean AND operation between each pair of matching bits in two operands
- Syntax: (OF=0,CF=0,SF,ZF,PF)

AND destination, source

(same operand types as MOV)

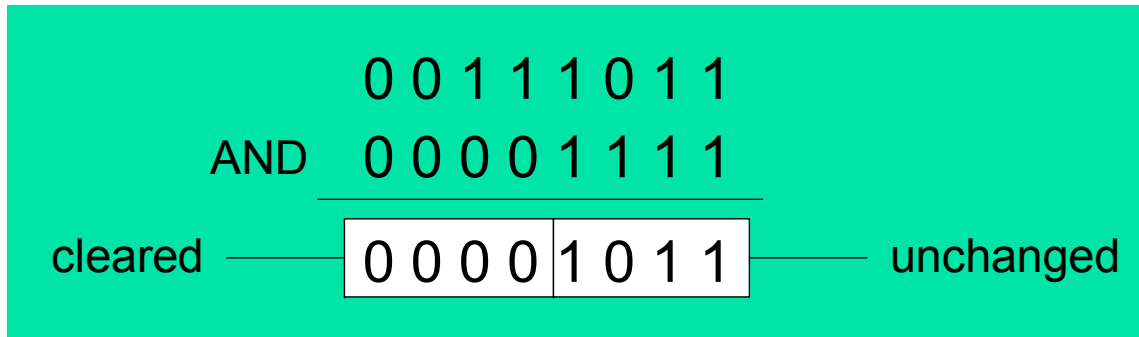

AND

x	y	$x \wedge y$
0	0	0
0	1	0
1	0	0
1	1	1

OR Instruction

- Performs a Boolean OR operation between each pair of matching bits in two operands
- Syntax: (OF=0,CF=0,SF,ZF,PF)

OR *destination, source*

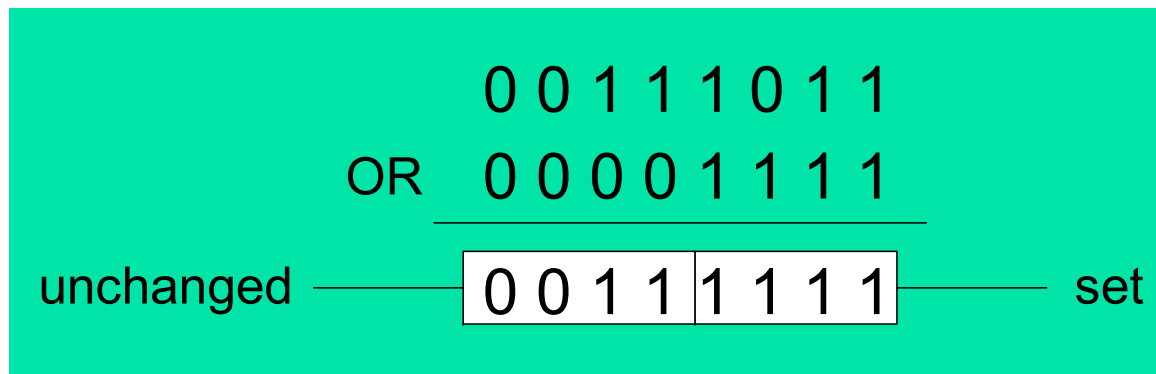

OR

x	y	$x \vee y$
0	0	0
0	1	1
1	0	1
1	1	1

XOR Instruction

- Performs a Boolean exclusive-OR operation between each pair of matching bits in two operands
- Syntax: (OF=0,CF=0,SF,ZF,PF)
XOR destination, source

```
      0 0 1 1 1 0 1 1
XOR   0 0 0 0 1 1 1 1
-----
unchanged 0 0 1 1 | 0 1 0 0 inverted
```

XOR

x	y	$x \oplus y$
0	0	0
0	1	1
1	0	1
1	1	0

XOR is a useful way to invert the bits in an operand.

NOT Instruction

- Performs a Boolean NOT operation on a single destination operand
- Syntax: (no flag affected)

NOT *destination*

```
NOT  0 0 1 1 1 0 1 1
      ───────────
      1 1 0 0 0 1 0 0  ——— inverted
```

NOT

X	$\neg X$
F	T
T	F



Applications (1 of 5)

- Task: Convert the character in AL to upper case.
- Solution: Use the AND instruction to clear bit 5.

```
mov al, 'a'           ; AL = 01100001b
and al, 11011111b    ; AL = 01000001b
```



Applications (2 of 5)

- Task: Convert a binary decimal byte into its equivalent ASCII decimal digit.
- Solution: Use the OR instruction to set bits 4 and 5.

```
mov  al,6                ; AL = 00000110b  
or   al,00110000b       ; AL = 00110110b
```

The ASCII digit '6' = 00110110b



Applications (3 of 5)

- Task: Turn on the keyboard CapsLock key
- Solution: Use the OR instruction to set bit 6 in the keyboard flag byte at 0040:0017h in the BIOS data area.

```
mov ax,40h                ; BIOS segment
mov ds,ax
mov bx,17h                ; keyboard flag byte
or BYTE PTR [bx],01000000b ; CapsLock on
```

This code only runs in Real-address mode, and it does not work under Windows NT, 2000, or XP.



Applications (4 of 5)

- Task: Jump to a label if an integer is even.
- Solution: AND the lowest bit with a 1. If the result is Zero, the number was even.

```
mov ax,wordVal
and ax,1           ; low bit set?
jz  EvenValue     ; jump if Zero flag set
```



Applications (5 of 5)

- Task: Jump to a label if the value in AL is not zero.
- Solution: OR the byte with itself, then use the JNZ (jump if not zero) instruction.

```
or  al,al  
jnz IsNotZero      ; jump if not zero
```

ORing any number with itself does not change its value.



TEST Instruction

- Performs a nondestructive AND operation between each pair of matching bits in two operands
- No operands are modified, but the flags is affected.
- Example: jump to a label if either bit 0 or bit 1 in AL is set.

```
test al,00000011b
jnz ValueFound
```

- Example: jump to a label if neither bit 0 nor bit 1 in AL is set.

```
test al,00000011b
jz ValueNotFound
```



CMP Instruction (1 of 3)

- Compares the destination operand to the source operand
 - Nondestructive subtraction of source from destination (destination operand is not changed)
- Syntax: *CMP destination, source* (OF,SF,ZF,CF,AF,PF)
- Example: destination == source (unsigned)

```
mov al,5  
cmp al,5           ; Zero flag set
```

- Example: destination < source (unsigned)

```
mov al,4  
cmp al,5           ; Carry flag set
```



CMP Instruction (2 of 3)

- Example: destination > source (unsigned)

```
mov al,6  
cmp al,5           ; ZF = 0, CF = 0
```

(both the Zero and Carry flags are clear)



CMP Instruction (3 of 3)

- Example: destination > source (signed)

```
mov al,5  
cmp al,-2          ; Sign flag == Overflow flag
```

- Example: destination < source (signed)

```
mov al,-1  
cmp al,5          ; Sign flag != Overflow flag
```



Setting and Clearing Flags

```
and al, 0           ; set Zero
or  al, 1           ; clear Zero
or  al, 80h         ; set Sign
and al, 7Fh         ; clear Sign
stc                 ; set Carry
clc                 ; clear Carry

mov al, 7Fh
inc al              ; set Overflow

or  eax, 0          ; clear Overflow
```



What's Next

- Boolean and Comparison Instructions
- **Conditional Jumps**
- Conditional Loop Instructions
- Conditional Structures
- Application: Finite-State Machines
- Decision Directives



Conditional Structures

- There are no high-level logic structures such as if-then-else, in the IA-32 instruction set. But, you can use combinations of comparisons and jumps to implement any logic structure.
- First, an operation such as CMP, AND or SUB is executed to modified the CPU flags. Second, a conditional jump instruction tests the flags and change the execution flow accordingly.

```
        CMP AL, 0
        JZ  L1
        :
L1:
```



Jcond Instruction

- A conditional jump instruction branches to a label when specific register or flag conditions are met
- Examples:
 - JB, JC jump to a label if the Carry flag is set
 - JE, JZ jump to a label if the Zero flag is set
 - JS jumps to a label if the Sign flag is set
 - JNE, JNZ jump to a label if the Zero flag is clear
 - JECXZ jumps to a label if ECX equals 0



Conditional Jumps

- Jumps Based On . . .
 - Specific flags
 - Equality
 - Unsigned comparisons
 - Signed Comparisons
- Applications
- Encrypting a String
- Bit Test (BT) Instruction



Jcond Ranges

- Prior to the 386:
 - jump must be within -128 to $+127$ bytes from current location counter
- IA-32 processors:
 - 32-bit offset permits jump anywhere in memory



Jumps Based on Specific Flags

Mnemonic	Description	Flags
JZ	Jump if zero	ZF = 1
JNZ	Jump if not zero	ZF = 0
JC	Jump if carry	CF = 1
JNC	Jump if not carry	CF = 0
JO	Jump if overflow	OF = 1
JNO	Jump if not overflow	OF = 0
JS	Jump if signed	SF = 1
JNS	Jump if not signed	SF = 0
JP	Jump if parity (even)	PF = 1
JNP	Jump if not parity (odd)	PF = 0



Jumps Based on Equality

Mnemonic	Description
JE	Jump if equal (<i>leftOp = rightOp</i>)
JNE	Jump if not equal (<i>leftOp ≠ rightOp</i>)
JCXZ	Jump if CX = 0
JECXZ	Jump if ECX = 0



Jumps Based on Unsigned Comparisons

Mnemonic	Description
JA	Jump if above (if $leftOp > rightOp$)
JNBE	Jump if not below or equal (same as JA)
JAE	Jump if above or equal (if $leftOp \geq rightOp$)
JNB	Jump if not below (same as JAE)
JB	Jump if below (if $leftOp < rightOp$)
JNAE	Jump if not above or equal (same as JB)
JBE	Jump if below or equal (if $leftOp \leq rightOp$)
JNA	Jump if not above (same as JBE)



Jumps Based on Signed Comparisons

Mnemonic	Description
JG	Jump if greater (if $leftOp > rightOp$)
JNLE	Jump if not less than or equal (same as JG)
JGE	Jump if greater than or equal (if $leftOp \geq rightOp$)
JNL	Jump if not less (same as JGE)
JL	Jump if less (if $leftOp < rightOp$)
JNGE	Jump if not greater than or equal (same as JL)
JLE	Jump if less than or equal (if $leftOp \leq rightOp$)
JNG	Jump if not greater (same as JLE)



Applications (1 of 5)

- Task: Jump to a label if **unsigned** EAX is greater than EBX
- Solution: Use CMP, followed by JA

```
cmp eax, ebx  
ja  Larger
```

- Task: Jump to a label if **signed** EAX is greater than EBX
- Solution: Use CMP, followed by JG

```
cmp eax, ebx  
jg  Greater
```



Applications (2 of 5)

- Jump to label L1 if **unsigned** EAX is less than or equal to Val1

```
cmp eax,Val1  
jbe L1          ; below or equal
```

- Jump to label L1 if **signed** EAX is less than or equal to Val1

```
cmp eax,Val1  
jle L1
```



Applications (3 of 5)

- Compare unsigned AX to BX, and copy the larger of the two into a variable named **Large**

```
mov Large,bx
cmp ax,bx
jna Next
mov Large,ax
Next:
```

- Compare signed AX to BX, and copy the smaller of the two into a variable named **Small**

```
mov Small,ax
cmp bx,ax
jnl Next
mov Small,bx
Next:
```



Applications (4 of 5)

- Jump to label L1 if the memory word pointed to by ESI equals Zero

```
cmp WORD PTR [esi],0
je L1
```

- Jump to label L2 if the doubleword in memory pointed to by EDI is even

```
test DWORD PTR [edi],1
jz L2
```



Applications (5 of 5)

- Task: Jump to label L1 if bits 0, 1, and 3 in AL are **all set**.
- Solution: Clear all bits except bits 0, 1, and 3. Then compare the result with 00001011 binary.

```
and al,00001011b      ; clear unwanted bits
cmp al,00001011b      ; check remaining bits
je L1                  ; all set? jump to L1
```



Example: Scanning a Array

- Find the first even number in an array of unsigned integers

```
.date
intArray DWORD 7,9,3,4,6,1
.code
...
        mov  ebx, OFFSET intArray
        mov  ecx, LENGTHOF intArray
L1:     test  DWORD PTR [ebx], 1
        jz   found
        add  ebx, 4
        loop L1
...

```

Example: Encrypting a String

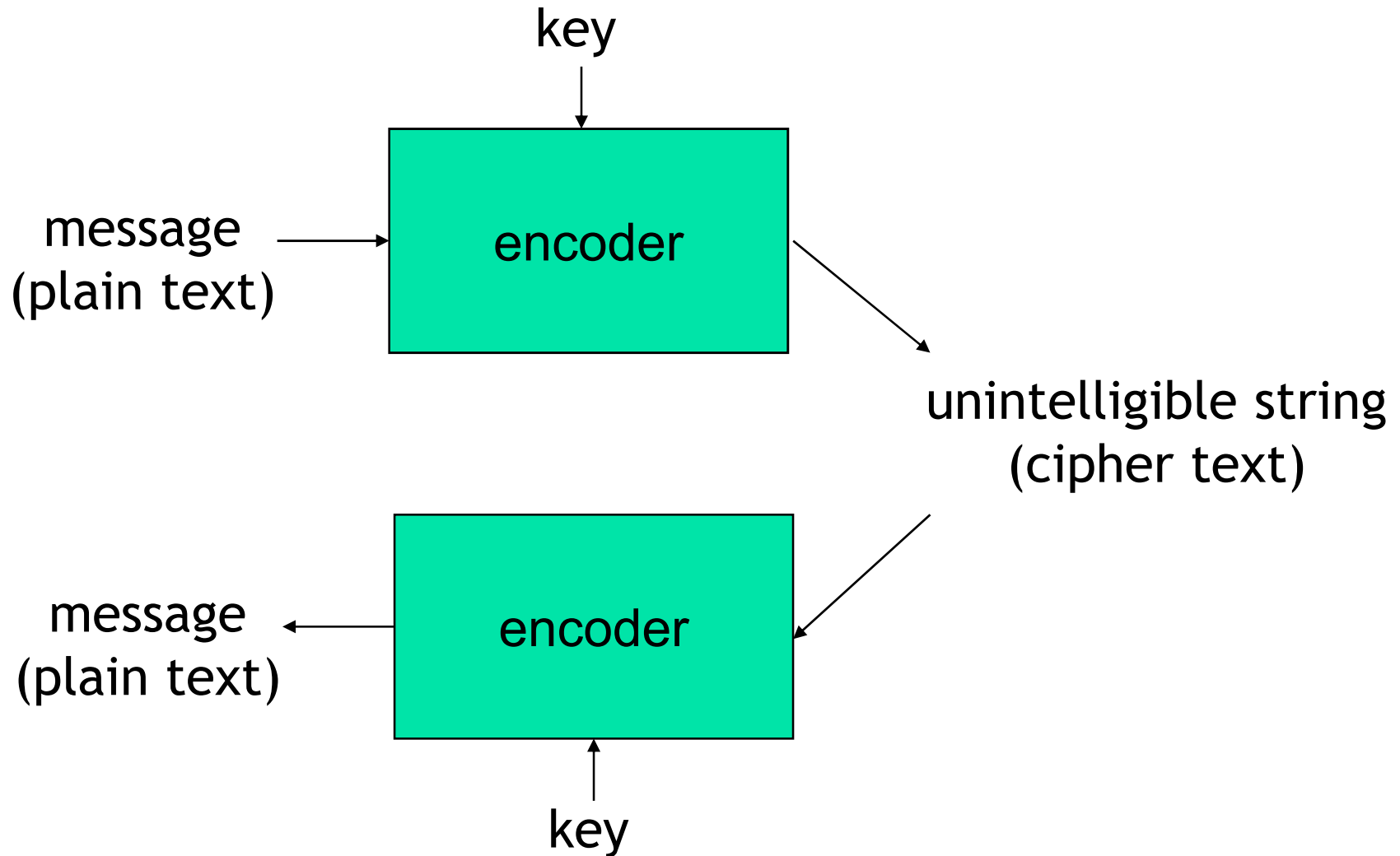



Example: Encrypting a String

The following loop uses the XOR instruction to transform every character in a string into a new value.

```
KEY = 239                ; can be any byte value
BUFMAX = 128
.data
buffer BYTE BUFMAX+1 DUP(0)
bufSize DWORD BUFMAX

.code
    mov ecx,bufSize      ; loop counter
    mov esi,0            ; index 0 in buffer
L1:
    xor buffer[esi],KEY  ; translate a byte
    inc esi              ; point to next byte
    loop L1
```



String Encryption Program

- **Tasks:**

- Input a message (string) from the user
- Encrypt the message
- Display the encrypted message
- Decrypt the message
- Display the decrypted message

```
Enter the plain text: Attack at dawn.
```

```
Cipher text: «ççÄîä-Äç-ïÄÿü-Gs
```

```
Decrypted: Attack at dawn.
```



What's Next

- Boolean and Comparison Instructions
- Conditional Jumps
- **Conditional Loop Instructions**
- Conditional Structures
- Application: Finite-State Machines
- Decision Directives



Conditional Loop Instructions

- LOOPZ and LOOPE
- LOOPNZ and LOOPNE



LOOPZ and LOOPE

- Syntax:
 - LOOPE *destination*
 - LOOPZ *destination*
- Logic:
 - $ECX \leftarrow ECX - 1$
 - if $ECX > 0$ and $ZF=1$, jump to *destination*
- Useful when scanning an array for the first element that does **not** match a given value.



LOOPNZ and LOOPNE

- LOOPNZ (LOOPNE) is a conditional loop instruction

- Syntax:

 LOOPNZ *destination*

 LOOPNE *destination*

- Logic:

- $ECX \leftarrow ECX - 1;$

- if $ECX > 0$ and $ZF=0$, jump to *destination*

- Useful when scanning an array for the first element that matches a given value.



LOOPNZ Example

The following code finds the first positive value in an array:

```
.data
array SWORD -3,-6,-1,-10,10,30,40,4
sentinel SWORD 0
.code
    mov esi,OFFSET array
    mov ecx,LENGTHOF array
next:
    test WORD PTR [esi],8000h ; test sign bit
    pushfd ; push flags on stack
    add esi,TYPE array
    popfd ; pop flags from stack
    loopnz next ; continue loop
    jnz quit ; none found
    sub esi,TYPE array ; ESI points to value
quit:
```



Your turn . . .

Locate the first nonzero value in the array. If none is found, let ESI point to the sentinel value:

```
.data
array  SWORD 50 DUP(?)
sentinel  SWORD 0FFFFh
.code
    mov esi,OFFSET array
    mov ecx,LENGTHOF array
L1:  cmp WORD PTR [esi],0           ; check for zero
```

(fill in your code here)

```
quit:
```



... (solution)

```
.data
array SWORD 50 DUP(?)
sentinel SWORD 0FFFFh
.code
    mov esi,OFFSET array
    mov ecx,LENGTHOF array
L1: cmp WORD PTR [esi],0           ; check for zero
    pushfd                       ; push flags on stack
    add esi,TYPE array
    popfd                        ; pop flags from stack
    loope L1                     ; continue loop
    jz quit                      ; none found
    sub esi,TYPE array           ; ESI points to value
quit:
```



What's Next

- Boolean and Comparison Instructions
- Conditional Jumps
- Conditional Loop Instructions
- **Conditional Structures**
- Application: Finite-State Machines
- Decision Directives



Conditional Structures

- Block-Structured IF Statements
- Compound Expressions with AND
- Compound Expressions with OR
- WHILE Loops
- Table-Driven Selection



Block-Structured IF Statements

Assembly language programmers can easily translate logical statements written in C++/Java into assembly language. For example:

```
if( op1 == op2 )
    X = 1;
else
    X = 2;
```

```
mov eax,op1
cmp eax,op2
jne L1
mov X,1
jmp L2
L1: mov X,2
L2:
```



Your turn . . .

Implement the following pseudocode in assembly language. All values are unsigned:

```
if( ebx <= ecx )
{
    eax = 5;
    edx = 6;
}
```

```
cmp ebx,ecx
ja next
mov eax,5
mov edx,6
next:
```

(There are multiple correct solutions to this problem.)



Your turn . . .

Implement the following pseudocode in assembly language. All values are 32-bit signed integers:

```
if( var1 <= var2 )
    var3 = 10;
else
{
    var3 = 6;
    var4 = 7;
}
```

```
mov eax,var1
cmp eax,var2
jle L1
mov var3,6
mov var4,7
jmp L2
L1: mov var3,10
L2:
```

(There are multiple correct solutions to this problem.)



Compound Expression with AND (1 of 3)

- When implementing the logical AND operator, consider that HLLs use short-circuit evaluation
- In the following example, if the first expression is false, the second expression is skipped:

```
if (a1 > b1) AND (b1 > c1)  
    x = 1;
```



Compound Expression with AND (2 of 3)

```
if (a1 > b1) AND (b1 > c1)
    X = 1;
```

This is one possible implementation . . .

```
    cmp a1,b1                ; first expression...
    ja  L1
    jmp next
L1:
    cmp b1,c1                ; second expression...
    ja  L2
    jmp next
L2:                            ; both are true
    mov X,1                  ; set X to 1
next:
```



Compound Expression with AND (3 of 3)

```
if (a1 > b1) AND (b1 > c1)
    X = 1;
```

But the following implementation uses 29% less code by reversing the first relational operator. We allow the program to "fall through" to the second expression:

```
    cmp a1,b1                ; first expression...
    jbe next                 ; quit if false
    cmp b1,c1                ; second expression...
    jbe next                 ; quit if false
    mov X,1                  ; both are true
next:
```



Your turn . . .

Implement the following pseudocode in assembly language. All values are unsigned:

```
if( ebx <= ecx
    && ecx > edx )
{
    eax = 5;
    edx = 6;
}
```

```
cmp ebx,ecx
ja next
cmp ecx,edx
jbe next
mov eax,5
mov edx,6
next:
```

(There are multiple correct solutions to this problem.)



Compound Expression with OR (1 of 2)

- When implementing the logical OR operator, consider that HLLs use short-circuit evaluation
- In the following example, if the first expression is true, the second expression is skipped:

```
if (a1 > b1) OR (b1 > c1)  
  X = 1;
```



Compound Expression with OR (1 of 2)

```
if (a1 > b1) OR (b1 > c1)
    X = 1;
```

```
    cmp al,b1                ; is AL > BL?
    ja  L1                   ; yes
    cmp bl,c1                ; no: is BL > CL?
    jbe next                 ; no: skip next statement
L1: mov X,1                  ; set X to 1
next:
```



WHILE Loops

A WHILE loop is really an IF statement followed by the body of the loop, followed by an unconditional jump to the top of the loop. Consider the following example:

```
while( eax < ebx)
    eax = eax + 1;
```

This is a possible implementation:

```
top: cmp  eax, ebx           ; check loop condition
     jae  next              ; false? exit loop
     inc  eax                ; body of loop
     jmp  top                ; repeat the loop
next:
```



Your Turn . . .

Implement the following loop, using unsigned 32-bit integers:

```
while( ebx <= val1)
{
    ebx = ebx + 5;
    val1 = val1 - 1
}
```

```
top: cmp ebx, val1          ; check loop condition
     ja  next              ; false? exit loop
     add ebx, 5             ; body of loop
     dec val1
     jmp top                ; repeat the loop
next:
```



Example: IF statement nested in a loop

```
while(eax < ebx)
{
    eax++;
    if (ebx==ecx)
        X=2;
    else
        X=3;
}
```

```
_while:  cmp    eax, ebx
         jae    _endwhile
         inc   eax
         cmp    ebx, ecx
         jne    _else
         mov   X, 2
         jmp   _while
_else:   mov   X, 3
         jmp   _while
_endwhile:
```



Table-Driven Selection (1 of 3)

- Table-driven selection uses a table lookup to replace a multiway selection structure
- Create a table containing lookup values and the offsets of labels or procedures
- Use a loop to search the table
- Suited to a large number of comparisons



Table-Driven Selection (2 of 3)

Step 1: create a table containing lookup values and procedure offsets:

```
.data
CaseTable BYTE 'A'           ; lookup value
          DWORD Process_A     ; address of procedure
          EntrySize = ($ - CaseTable)
          BYTE 'B'
          DWORD Process_B
          BYTE 'C'
          DWORD Process_C
          BYTE 'D'
          DWORD Process_D

NumberOfEntries = ($ - CaseTable) / EntrySize
```

Table-Driven Selection (3 of 3)

Step 2: Use a loop to search the table. When a match is found, we call the procedure offset stored in the current table entry:

```
    mov ebx,OFFSET CaseTable      ; point EBX to the table
    mov ecx,NumberOfEntries      ; loop counter

L1:  cmp al,[ebx]                ; match found?
     jne L2                      ; no: continue
     call NEAR PTR [ebx + 1]     ; yes: call the procedure
     jmp L3                      ; and exit the loop
L2:  add ebx,EntrySize          ; point to next entry
     loop L1                    ; repeat until ECX = 0

L3:
```

required for
procedure pointers



What's Next

- Boolean and Comparison Instructions
- Conditional Jumps
- Conditional Loop Instructions
- Conditional Structures
- **Application: Finite-State Machines**
- Decision Directives



Application: Finite-State Machines

- A finite-state machine (FSM) is a graph structure that changes state based on some input. Also called a **state-transition diagram**.
- We use a graph to represent an FSM, with squares or circles called **nodes**, and lines with arrows between the circles called **edges** (or arcs).
- A FSM is a specific instance of a more general structure called a **directed graph** (or digraph).
- Three basic states, represented by nodes:
 - Start/initial state
 - Terminal state(s)
 - Nonterminal state(s)



Finite-State Machine

- Accepts any sequence of symbols that puts it into an accepting (final) state
- Can be used to recognize, or validate a sequence of characters that is governed by language rules (called a regular expression)
- Advantages:
 - Provides visual tracking of program's flow of control
 - Easy to modify
 - Easily implemented in assembly language

FSM Examples

- FSM that recognizes strings beginning with 'x', followed by letters 'a'..'y', ending with 'z':

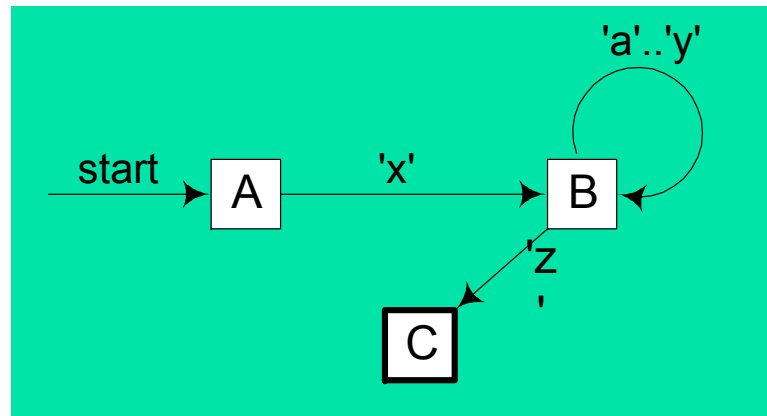

- FSM that recognizes signed integers:

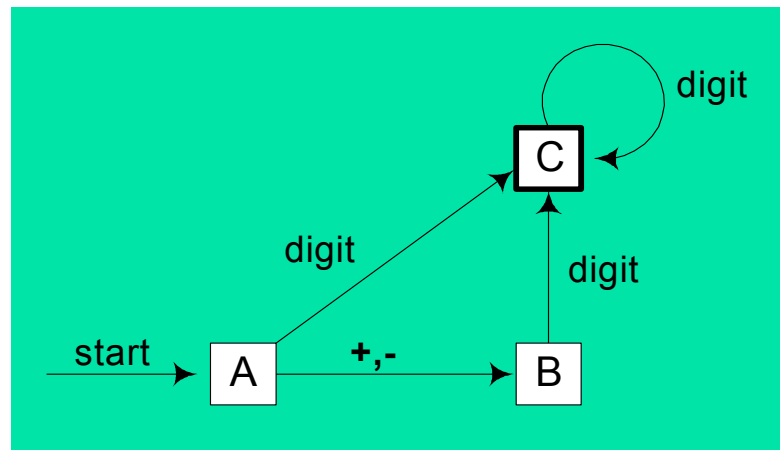

Your Turn . . .

- Explain why the following FSM does not work as well for signed integers as the one shown on the previous slide:

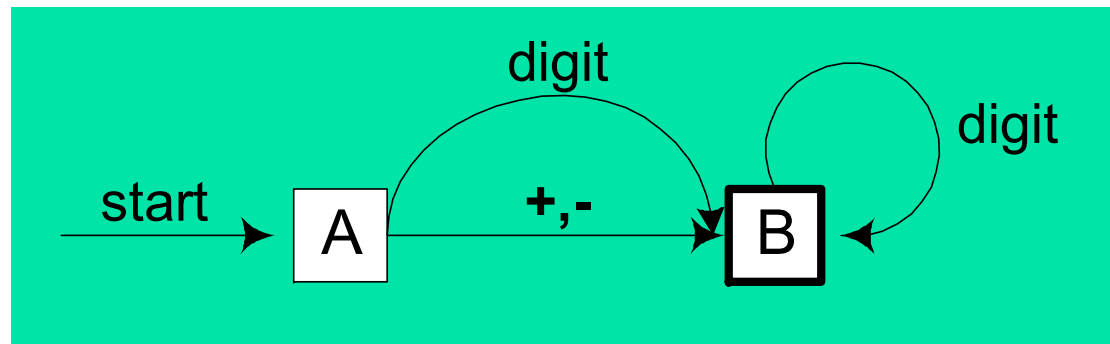

Implementing an FSM

The following is code from State A in the Integer FSM:

StateA:

```
call Getnext           ; read next char into AL
cmp al, '+'            ; leading + sign?
je StateB              ; go to State B
cmp al, '-'            ; leading - sign?
je StateB              ; go to State B
call IsDigit           ; ZF = 1 if AL = digit
jz StateC              ; go to State C
call DisplayErrorMsg   ; invalid input found
jmp Quit
```

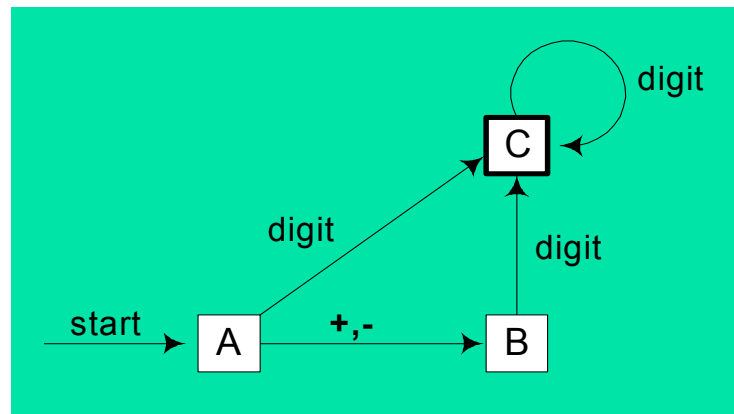



IsDigit Procedure

Receives a character in AL. Sets the Zero flag if the character is a decimal digit.

```
IsDigit PROC
    cmp    al,'0'           ; ZF = 0
    jb    ID1
    cmp    al,'9'         ; ZF = 0
    ja    ID1
    test   ax,0            ; ZF = 1
ID1: ret
IsDigit ENDP
```



What's Next

- Boolean and Comparison Instructions
- Conditional Jumps
- Conditional Loop Instructions
- Conditional Structures
- Application: Finite-State Machines
- **Decision Directives**



Runtime Expressions

- .IF, .ELSE, .ELSEIF, and .ENDIF can be used to create block-structured IF statements.
- Examples:

```
.IF eax > ebx
    mov edx, 1
.ELSE
    mov edx, 2
.ENDIF
```

```
.IF eax > ebx && eax > ecx
    mov edx, 1
.ELSE
    mov edx, 2
.ENDIF
```

- MASM generates "hidden" code for you, consisting of code labels, CMP and conditional jump instructions.



Relational and Logical Operators

Operator	Description
<i>expr1 == expr2</i>	Returns true when <i>expression1</i> is equal to <i>expr2</i> .
<i>expr1 != expr2</i>	Returns true when <i>expr1</i> is not equal to <i>expr2</i> .
<i>expr1 > expr2</i>	Returns true when <i>expr1</i> is greater than <i>expr2</i> .
<i>expr1 >= expr2</i>	Returns true when <i>expr1</i> is greater than or equal to <i>expr2</i> .
<i>expr1 < expr2</i>	Returns true when <i>expr1</i> is less than <i>expr2</i> .
<i>expr1 <= expr2</i>	Returns true when <i>expr1</i> is less than or equal to <i>expr2</i> .
<i>! expr</i>	Returns true when <i>expr</i> is false.
<i>expr1 && expr2</i>	Performs logical AND between <i>expr1</i> and <i>expr2</i> .
<i>expr1 expr2</i>	Performs logical OR between <i>expr1</i> and <i>expr2</i> .
<i>expr1 & expr2</i>	Performs bitwise AND between <i>expr1</i> and <i>expr2</i> .
CARRY?	Returns true if the Carry flag is set.
OVERFLOW?	Returns true if the Overflow flag is set.
PARITY?	Returns true if the Parity flag is set.
SIGN?	Returns true if the Sign flag is set.
ZERO?	Returns true if the Zero flag is set.

MASM-Generated Code

```
.data
val1    DWORD 5
result  DWORD ?
.code
mov eax,6
.IF eax > val1
    mov result,1
.ENDIF
```

Generated code:

```
mov eax,6
cmp eax,val1
jbe @C0001
mov result,1
@C0001:
```

MASM automatically generates an unsigned jump (JBE) because `val1` is unsigned.

MASM-Generated Code

```
.data
val1    SDWORD 5
result SDWORD ?
.code
mov eax,6
.IF eax > val1
    mov result,1
.ENDIF
```

Generated code:

```
mov eax,6
cmp eax,val1
jle @C0001
mov result,1
@C0001:
```

MASM automatically generates a signed jump (JLE) because `val1` is signed.

MASM-Generated Code

```
.data
result DWORD ?
.code
mov ebx,5
mov eax,6
.IF eax > ebx
    mov result,1
.ENDIF
```

Generated code:

```
mov ebx,5
mov eax,6
cmp eax,ebx
jbe @C0001
mov result,1
@C0001:
```

MASM automatically generates an unsigned jump (JBE) when both operands are registers . . .



MASM-Generated Code

```
.data
result SDWORD ?
.code
mov ebx,5
mov eax,6
.IF SDWORD PTR eax > ebx
    mov result,1
.ENDIF
```

Generated code:

```
mov ebx,5
mov eax,6
cmp eax,ebx
jle @C0001
mov result,1
@C0001:
```

... unless you prefix one of the register operands with the SDWORD PTR operator. Then a signed jump is generated.



.REPEAT Directive

Executes the loop body before testing the loop condition associated with the .UNTIL directive.

Example:

```
; Display integers 1 - 10:

mov  eax,0
.REPEAT
    inc  eax
    call WriteDec
    call Crlf
.UNTIL  eax == 10
```



.WHILE Directive

Tests the loop condition before executing the loop body
The .ENDW directive marks the end of the loop.

Example:

```
; Display integers 1 - 10:  
  
mov  eax,0  
.WHILE  eax < 10  
    inc  eax  
    call WriteDec  
    call Crlf  
.ENDW
```

