

Course overview

Digital Image Synthesis
Yung-Yu Chuang

with slides by Mario Costa Sousa, Pat Hanrahan and Ravi Ramamoorthi

Logistics



- Meeting time: 2:20pm-5:20pm, Thursday
- Classroom: CSIE Room 111
- Instructor: Yung-Yu Chuang (cyy@csie.ntu.edu.tw)
- TA: 吳昱霆
- Webpage:
<http://www.csie.ntu.edu.tw/~cyy/rendering>
id/password
- Mailing list: rendering@cmlab.csie.ntu.edu.tw
Please subscribe via
<https://cmlmail.csie.ntu.edu.tw/mailman/listinfo/rendering/>

Prerequisites



- C++ programming experience is required.
- Basic knowledge on algorithm and data structure is essential.
- Knowledge on linear algebra, probability, calculus and numerical methods is a plus.
- Though not required, it is recommended that you have background knowledge on computer graphics.

Requirements (subject to change)



- 3 programming assignments (60%)
- Class participation (5%)
- Final project (35%)

Textbook



[Physically Based Rendering from Theory to Implementation](#),
2nd ed, by Matt Pharr and Greg Humphreys

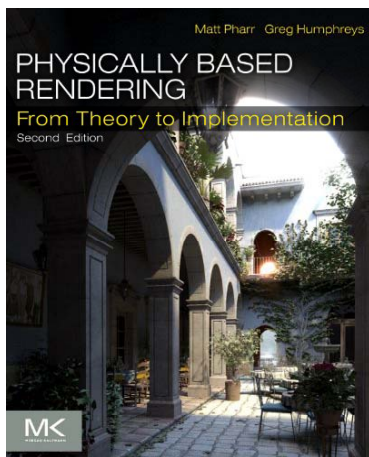

- Authors have a lot of experience on ray tracing
- **Complete (educational) code, more concrete**
- Has been used in some courses and papers
- Implement some advanced or difficult-to-implement methods: subdivision surfaces, Metropolis sampling, BSSRDF, PRT.

pbrt



- Pbrt is designed to be
 - Complete: includes features found in commercial high-quality renderers.
 - Illustrative: select and implement elegant methods.
 - Physically based
- Efficiency was given a lower priority (the unofficial fork [luxrender](#) could be more efficient)
- [Source code browser](#)

New features of pbrt2



- Remove plug-in architecture, but still an extensible architecture
- Add multi-thread support (automatic or --ncores)
- OpenEXR is recommended, not required
- HBV is added and becomes default
- Can be full spectral, do it at compile time
- Animation is supported
- Instant global illumination, extended photon map, extended infinite light source
- Improved irradiance cache

New features



- BSSRDF is added
- Metropolis light transport
- Precomputed radiance transfer
- Support measured BRDF

Literate programming



- A programming paradigm proposed by Knuth when he was developing Tex.
- Programs should be written more for people's consumption than for computers' consumption.
- The whole book is a long literate program. That is, when you read the book, you also read a complete program.

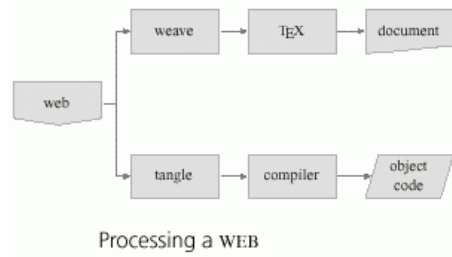

Features



- Mix prose with source: description of the code is as important as the code itself
- Allow presenting the code to the reader in a different order than to the compiler
- Easy to make index
- Traditional text comments are usually not enough, especially for graphics
- This decomposition lets us present code a few lines at a time, making it easier to understand.
- It looks more like pseudo code.

LP example



@\section{Selection Sort: An Example for LP}

We use {\it selection sort} to illustrate the concept of {it literate programming}.

Selection sort is one of the simplest sorting algorithms. It first find the smallest element in the array and exchange it with the element in the first position, then find the second smallest element and exchange it the element in the second position, and continue in this way until the entire array is sorted.

The following code implement the procedure for selection sort assuming an external array [[a]].

```
<<*>>=
<<external variables>>
void selection_sort(int n) {
  <<init local variables>>
  for (int i=0; i<n-1; i++) {
    <<find minimum after the ith element>>
    <<swap current and minimum>>
  }
}
```

LP example



```
<<find minimum after the ith element>>=
min=i;
for (int j=i+1; j<n; j++) {
  if (a[j]<a[min]) min=j;
}
```

```
<<init local variables>>=
int min;
```

@ To swap two variables, we need a temporary variable [[t]] which is declared at the beginning of the procedure.

```
<<init local variables>>=
int t;
```

@ Thus, we can use [[t]] to preserve the value of [[a[min]]] so that the swap operation works correctly.

```
<<swap current and minimum>>=
t=a[min]; a[min]=a[i]; a[i]=t;
```

```
<<external variables>>=
int *a;
```

LP example (tangle)



```
int *a;

void selection_sort(int n) {
    int min;

    int t;

    for (int i=0; i<n-1; i++) {
        min=i;
        for (int j=i+1; j<n; j++) {
            if (a[j]<a[min]) min=j;
        }

        t=a[min]; a[min]=a[i]; a[i]=t;
    }
}
```

LP example (weave)



1 Selection Sort: An Example for LP

We use *selection sort* to illustrate the concept of iterative programming. Selection sort is one of the simplest sorting algorithms. It first finds the smallest element in the array and exchanges it with the element in the first position, then finds the second smallest element and exchanges it with the element in the second position, and continues in this way until the entire array is sorted. The following code implements the procedure for selection sort assuming an external array *a*.

```
1a  (* 1a)≡
    (external variables 1f)
    void selection_sort(int n) {
        (init local variables 1c)
        for (int i=0; i<n-1; i++) {
            (find minimum after the ith element 1b)
            (swap current and minimum 1e)
        }
    }

1b  (find minimum after the ith element 1b)≡ (1a)
    min=i;
    for (int j=i+1; j<n; j++) {
        if (a[j]<a[min]) min=j;
    }
```

Reference books



References



- SIGGRAPH proceedings
- SIGGRAPH Asia proceedings
- Proceedings of Eurographics Symposium on Rendering
- Eurographics proceedings
- Most can be found at [this link](#).

Image synthesis (Rendering)



- Create a 2D picture of a 3D world



Computer graphics

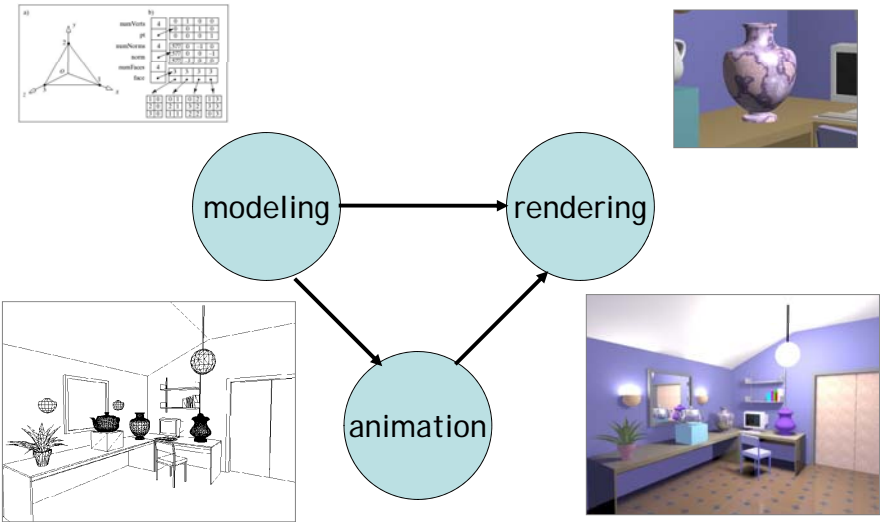



Physically-based rendering



uses physics to simulate the interaction between matter and light, realism is the primary goal



Realism



- Shadows
- Reflections (Mirrors)
- Transparency
- Interreflections
- Detail (Textures...)
- Complex Illumination
- Realistic Materials
- And many more



Other types of rendering



- Non-photorealistic rendering
- Image-based rendering
- Point-based rendering
- Volume rendering
- Perceptual-based rendering
- Artistic rendering

Pinhole camera

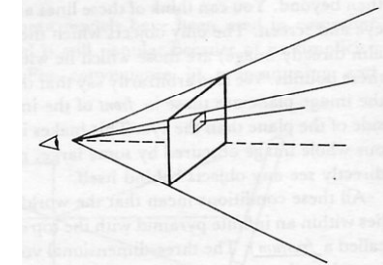
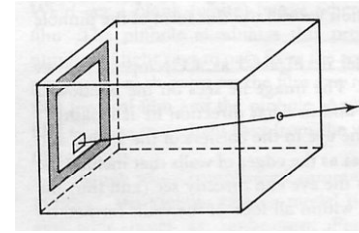

Introduction to ray tracing

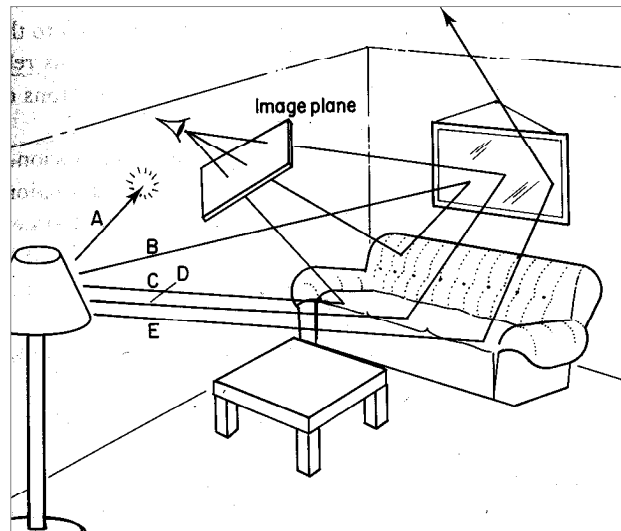

Ray Casting (Appel, 1968)

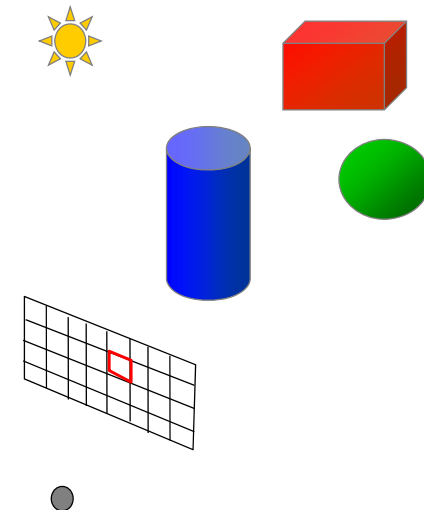

Ray Casting (Appel, 1968)

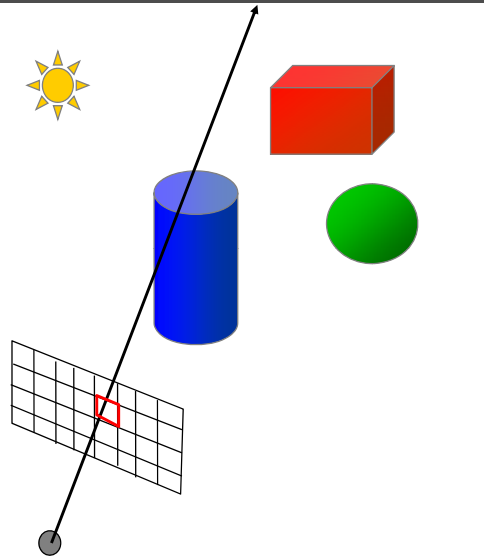

Ray Casting (Appel, 1968)

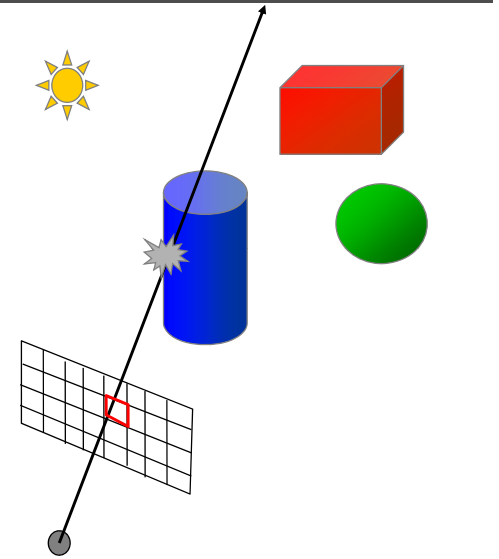

Ray Casting (Appel, 1968)



$$k_a I_a + \sum_{i=1}^{nls} I_i (k_d (L_i \cdot N) + k_s (R_i \cdot V)^n)$$

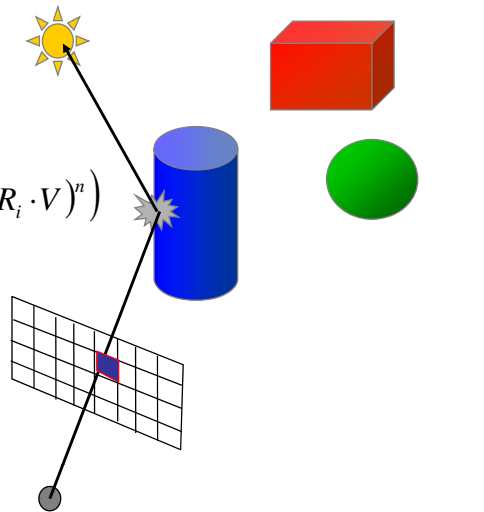

Ray Casting (Appel, 1968)

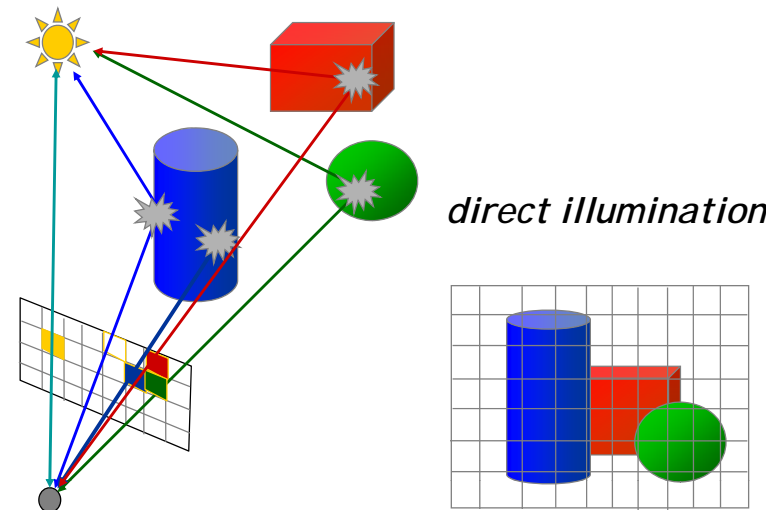

Whitted ray tracing algorithm



- ◆ Combines eye ray tracing + rays to light
- ◆ Recursively traces rays

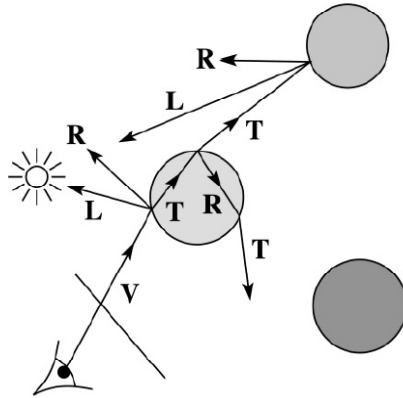

Whitted ray tracing algorithm



1. For each pixel, trace a **primary ray** in direction \mathbf{V} to the first visible surface.
2. For each intersection, trace **secondary rays**:
 - ◆ **Shadow rays** in directions \mathbf{L}_i to light sources
 - ◆ **Reflected ray** in direction \mathbf{R} .
 - ◆ **Refracted ray or transmitted ray** in direction \mathbf{T} .

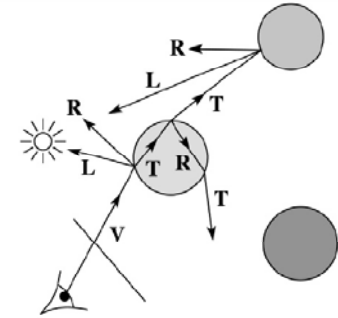

Shading



If $I(P_0, \mathbf{u})$ is the intensity seen from point P along direction \mathbf{u}

$$I(P_0, \mathbf{u}) = I_{direct} + I_{reflected} + I_{transmitted}$$

where

$I_{direct} = \text{Shade}(\mathbf{N}, \mathbf{L}, \mathbf{u}, \mathbf{R})$ (e.g. Phong shading model)

$I_{reflected} = k_r I(P, \mathbf{R})$

$I_{transmitted} = k_t I(P, \mathbf{T})$

Typically, we set $k_r = k_s$ and k_t

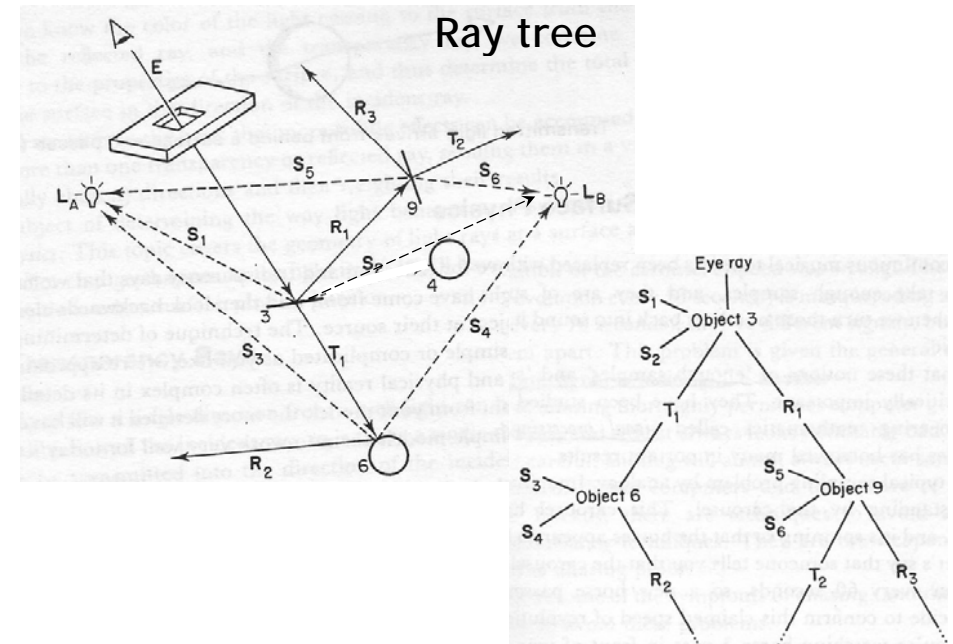
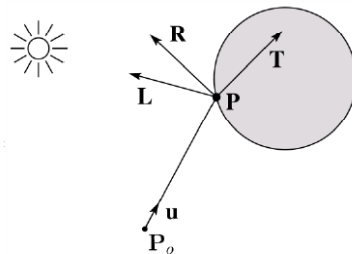

Recursive ray tracing (Whitted, 1980)

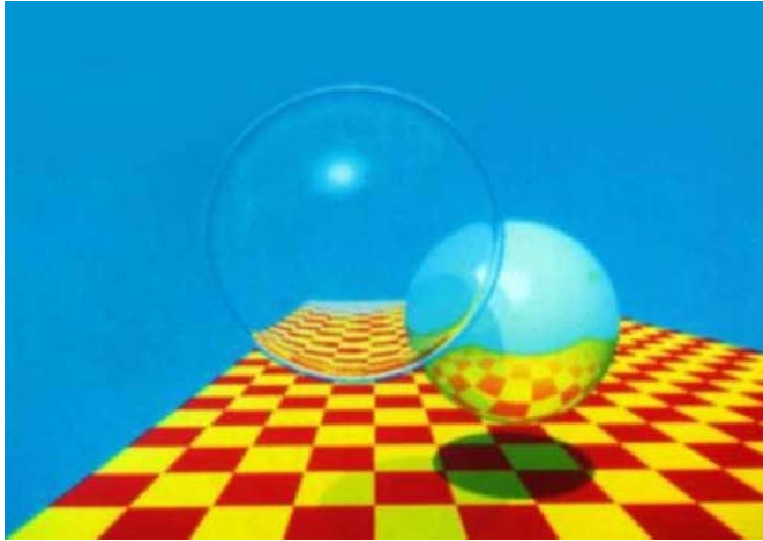

Components of a ray tracer

- Cameras
- Films
- Lights
- Ray-object intersection
- Visibility
- Surface scattering
- Recursive ray tracing

Minimal ray tracer

- Minimal ray tracer contest on *comp.graphics*, 1987
- Write the shortest Whitted-style ray tracer in C with the minimum number of tokens. The scene is consisted of spheres. (specular reflection and refraction, shadows)
- Winner: 916 tokens
- Cheater: 66 tokens (hide source in a string)
- Almost all entries have six modules: main, trace, intersect-sphere, vector-normalize, vector-add, dot-product.

Minimal ray tracer (Heckbert 1994)

```
typedef struct{double x,y,z}vec;vec U,black,amb={.02,.02,.02};struct sphere{ vec cen,color;
double rad,kd,ks,kt,kl,lr}*s,*best,sph[]={0.6...5,1.,1...9. .05..2. .85,0.,1.7.-1.8.,-.5,1...5..2,1.,
.7.,.3,0,..05,1.2,1.,8.,-.5.,1.,.8., 1.,.3.,.7,0.,0.,1.2,3.,-6.,15.,1.,.8,1.,.7.,0.,0.,0.,.6,1.5,-3.,-3.,12.,
.8,1., 1.,.5.,0.,0.,0.,.5,1.5.};yx;double u,b,tmin,sqrt(),tan();double vdot(A,B)vec A ,B;{return A.x
*B.x+A.y*B.y+A.z*B.z;}vec vcomb(a,A,B)double a;vec A,B;{B.x+=a*A.x;B.y+=a*A.y;B.z+=a*A.z;
return B;}vec vunit(A)vec A;{return vcomb(1./sqrt( vdot(A,A)),A,black);}struct sphere*intersect
(P,D)vec P,D;{best=0;tmin=1e30;s= sph+5;while(s-->sph)b=vdot(D,U=vcomb(-1.,P,s->cen)),
u=b*b-vdot(U,U)+s->rad*s ->rad,u=u>0?sqrt(u):1e31,u=b-u>1e-7?b-u:b+u,tmin=u>=1e-7&&
u<tmin?best=s,u: tmin;return best;}vec trace(level,P,D)vec P,D;{double d,eta,e;vec N,color;
struct sphere*s,*l;if(!level--)return black;if(s=intersect(P,D));else return amb;color=amb;eta=
s->ir:d= -vdot(D,N=vunit(vcomb(-1.,P=vcomb(tmin,D,P),s->cen )));if(d<0)N=vcomb(-1.,N,black),
eta=1/eta,d= -d;l=sph+5;while(l-->sph)if((e=l ->kl*vdot(N,U=vunit(vcomb(-1.,P,l->cen))))>0&&
intersect(P,U)=l)color=vcomb(e ,l->color,color);U=s->color;color.x*=U.x;color.y*=U.y;color.z
*=U.z;e=1-eta* eta*(1-d*d);return vcomb(s->kt,e>0?trace(level,P,vcomb(eta,D,vcomb(eta*d-
sqrt (e),N,black)))black,vcomb(s->ks,trace(level,P,vcomb(2*d,N,D)),vcomb(s->kd, color,vcomb
(s->kl,U,black)))));}main(){printf("%d %d\n",32,32);while(yx<32*32) U.x=yx%32-32/2,U.z=32/2-
yx+/32,U.y=32/2/tan(25/114.5915590261),U=vcomb(255., trace(3,black,vunit(U)),black),printf
("%%.0f %%.0f %%.0f\n",U);}/*minray!*/
```

That's it?



- In this course, we will study how state-of-art ray tracers work.



Issues



- Better Lighting + Forward Tracing
- Texture Mapping
- Sampling
- Modeling
- Materials
- Motion Blur, Depth of Field, Blurry Reflection/Refraction
 - *Distributed Ray-Tracing*
- Improving Image Quality
- Acceleration Techniques (better structure, faster convergence)

Complex lighting



Complex lighting



Refraction/dispersion



Caustics



Realistic materials



Translucent objects



Texture and complex materials



Even more complex materials



Complex material (luxrender)

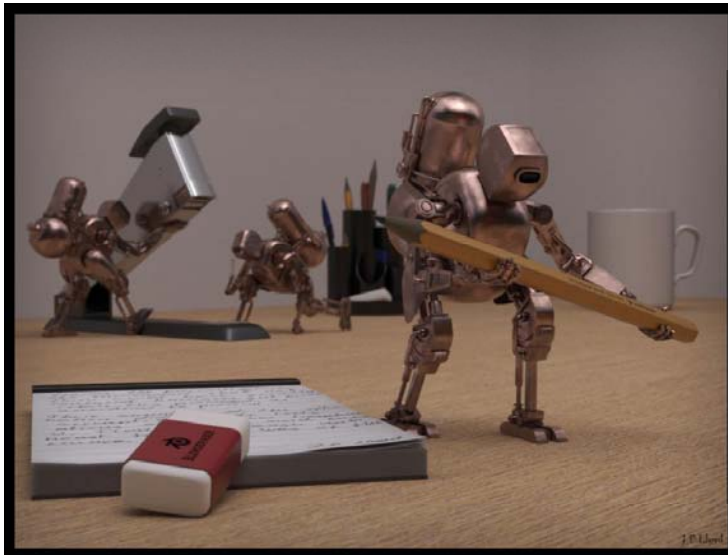

Depth of field (luxrender)



Motion blur (luxrender)



Refraction (Luxrender)



Applications



- Movies
- Interactive entertainment
- Industrial design
- Architecture
- Culture heritage



Animation production pipeline



story



text treatment



storyboard



voice



storyreal



look and feel

Animation production pipeline



modeling/articulation



layout



animation



shading/lighting



rendering



final touch

Homework #0



- Download and install pbrt 2.00 (Linux version is recommended.)
- Run several examples
- Set it up in a debugger environment so that you can trace the code
- Optionally, create your own scene